



X70

Gas Conveyor Oven



Project _____

Item No. _____

Quantity _____

PRINCIPLE

Middleby Marshall X-Series Conveyor ovens bake both faster and at a lower temperature than other ovens. Patented vertical columns of hot air move heat aerodynamically instead of using high temperatures. The streams of hot air remove the boundary layers of cool heavy air which tend to insulate the product. This allows for rapid results without burning.

STANDARD FEATURES

- 70" (1778 mm) long cooking chamber
- Patented "Jet Sweep" impingement process delivers constant heat to the chamber
- IoT compatible with Open Kitchen (ConnectWare required)
- Reversible conveyor belt provides automatic delivery when product is finished
- Front-loading window with cool handle design allows products with different bake times to be cooked consistently regardless of loading
- Removable parts for easy cleaning (crumb pans, end panels, air fingers, and a folding conveyor belt assembly)
- Stackable up to three high
- One-year parts and labor warranty – includes oven start-up and demonstration (U.S. only)

OPTIONAL FEATURES

- Compatible with Halton hood
- Split belt available upon request
- Hearth belt available

ENERGY MANAGEMENT SYSTEM (EMS)

- Patented EMS provides efficient heat transfer to and from the product
- Efficient heat transfer combined with streams of hot air means these ovens can cook a multitude of products in a fraction of the time
- The front of the oven is insulated so it is cool to the touch

CERTIFICATIONS



Middleby Marshall reserves the right to make substitutions of components or change specifications without prior notice.

DOC-1016/Revision B/January 2021

X70

Gas Conveyor Oven

GENERAL SPECIFICATIONS

Wall Clearance

Rear of Conveyor to Wall	4"	101.6 mm
Control End to Wall	6"	152.4 mm
Non-control End to Wall	6"	152.4 mm
Bake Operating Temperature	300°F-600°F	149°C-315°C
Time Range	1-19 minutes	

DIMENSIONS

Single Units

Heating Zone	70"	1778 mm
Belt Length	106.1"	2695 mm
Belt Width	32"	813 mm
Overall Length	106.1"	2695 mm
Height	43.22"	1098 mm
Depth	59.14"	1502 mm

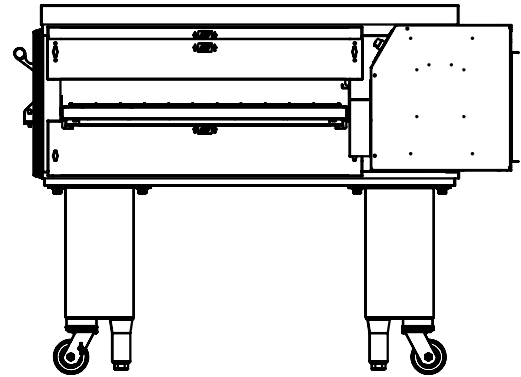

X70 Side View – Gas Single Unit

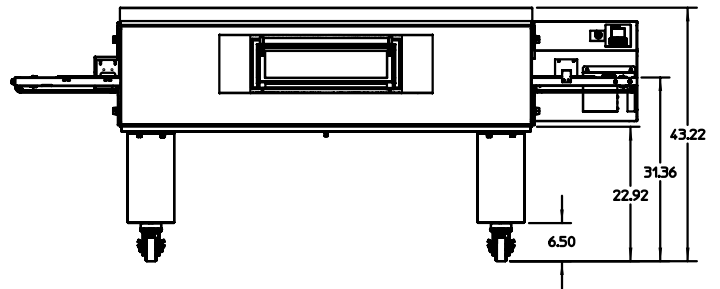

X70 Front View – Gas, Single Unit

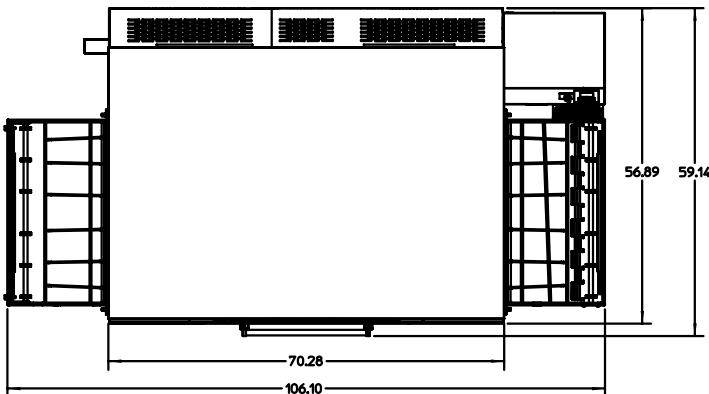

X70 Top View – Gas Single Unit

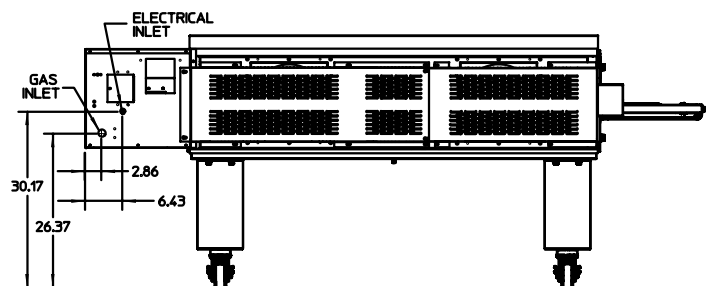

X70 Back View – Gas, Single Unit

* Height dimensions are shown for standard leg extensions. Customer-specific leg extensions will affect these dimensions. All units are shown with casters. CE-approved ovens use 6" (152 mm) adjustable feet instead of casters.

X70

Gas Conveyor Oven

DIMENSIONS

Double Stack Units

Heating Zone	70"	1778 mm
Belt Length	106.1"	2695 mm
Overall Length	106.1"	2695 mm
Height	56.27"	1429 mm
Depth	59.14"	1502 mm

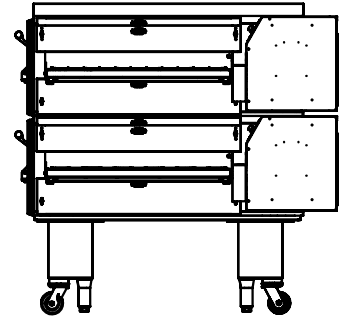

X70 Side View – Gas Double Unit

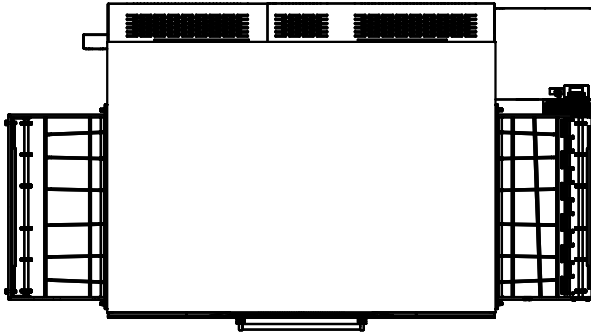

X70 Top View – Gas Double Unit

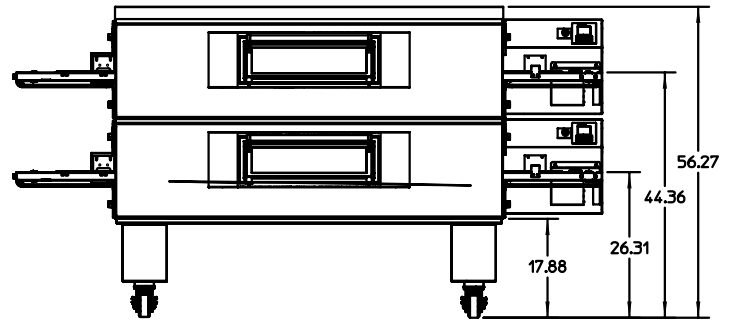

X70 Front View – Gas, Double Unit

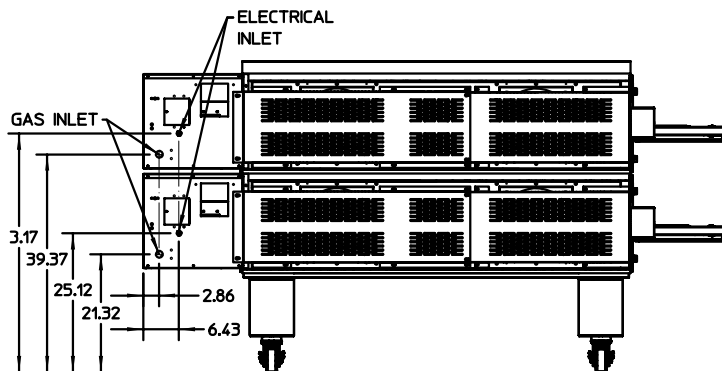

X70 Back View – Gas, Double Unit

* Height dimensions are shown for standard leg extensions. Customer-specific leg extensions will affect these dimensions. All units are shown with casters. CE-approved ovens use 6" (152 mm) adjustable feet instead of casters.

X70

Gas Conveyor Oven

DIMENSIONS

Triple Stack Units

Heating Zone	70"	1778 mm
Belt Length	106.1"	2695 mm
Overall Length	106.1"	2695 mm
Height	61.33"	1557.8 mm
Depth	59.14"	1502 mm

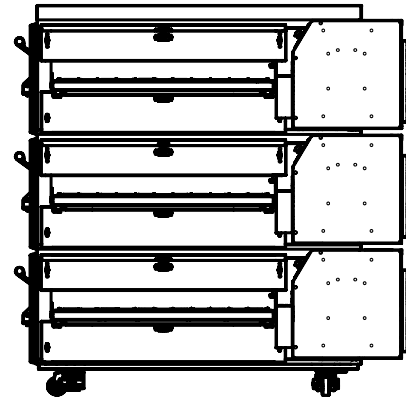

X70 Side View – Gas Triple Unit

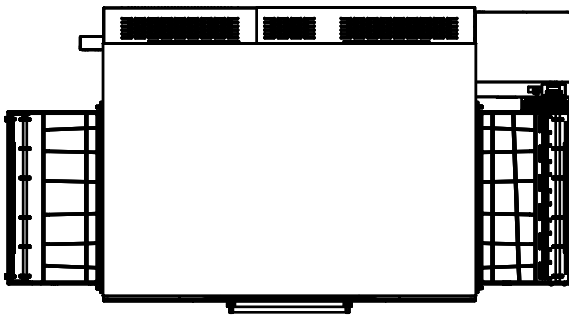

X70 Top View – Gas Triple Unit

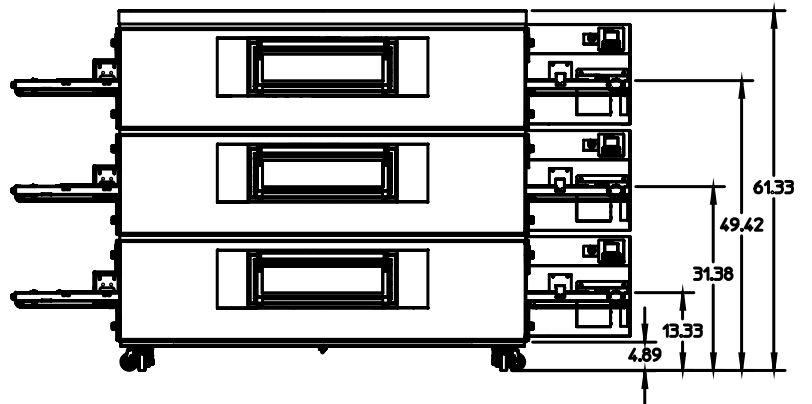

X70 Front View – Gas, Triple Unit

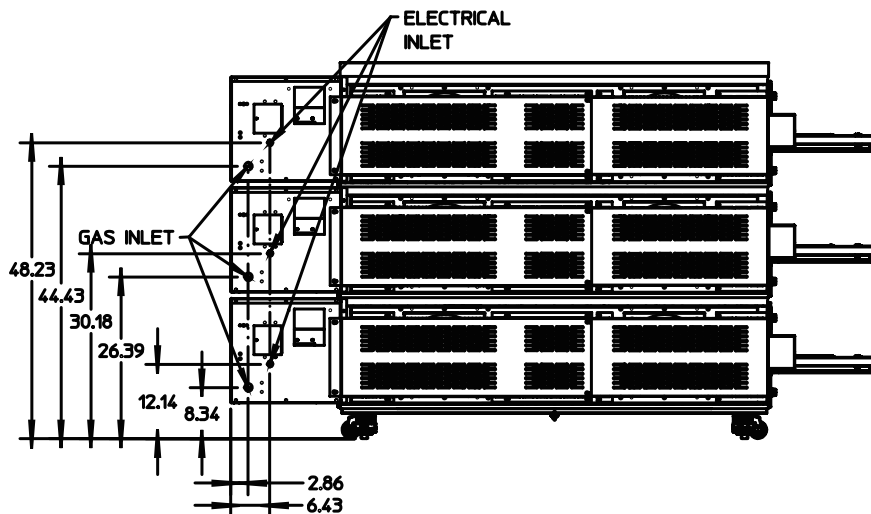

X70 Back View – Gas, Triple Unit

* Height dimensions are shown for standard leg extensions. Customer-specific leg extensions will affect these dimensions. All units are shown with casters. CE-approved ovens use 6" (152 mm) adjustable feet instead of casters.



X70

Gas Conveyor Oven

ELECTRICAL SPECIFICATIONS

Voltage	208/240 V
Phase	1
Frequency	50/60 Hz
Current Draw**	15A/13A
Supply	3-wire (2L)
Breakers	As per local code
Cord/Plug (Domestic Only)	6 ft cord with NEMA# L6-20P plug. Customer to provide NEMA# L6-20R receptical.

NATURAL GAS SPECIFICATIONS

Supply (Inlet) Pressure	6-12" W.C. (14.9-29.9 mbar)
Manifold Pressure	3.5" W.C. (8.7 mbar)
Rated Heat Input	160,000 BTU/HR (46.6 kW)

PROPANE GAS SPECIFICATIONS

Supply (Inlet) Pressure	11-14" W.C. (27.4-34.8 mbar)
Manifold Pressure	6" W.C. (14.9 mbar)
Rated Heat Input	160,000 BTU/HR (46.6 kW)

** The current draw rating shown above are maximum values for normal operation, amperage draw will be less than the listed value.
The required gas supply pressures of other locations are dependent on the local gas type and on all applicable local codes.

Minimum Gas Pipe Sizes:

Natural Gas - 2" (50.8 mm) main supply line. One 3/4" (19mm) NPT branch per oven cavity with individual full-flow shutoff valve.

Propane Gas - 2" (50.8 mm) main supply line. One 3/4" (19mm) NPT branch per oven cavity with individual full-flow shutoff valve

NOTE: Each oven includes (1) 3/4"(19mm)NPT x 48"(1219mm) flexible, vinyl coated gas hose, EXCEPT for CE Countries.