

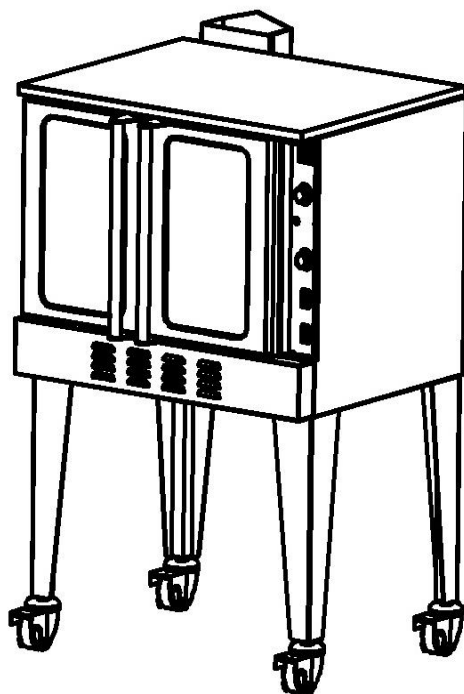

INSTALLATION & OPERATION MANUAL

Gas Convection Oven

MODEL: IGCO, IGCO-2



WARNING: IMPROPER INSTALLATION, ADJUSTMENT, ALTERATION, SERVICE OR MAINTENANCE CAN CAUSE PROPERTY DAMAGE, INJURY OR DEATH. READ THE INSTALLATION, OPERATING AND MAINTENANCE INSTRUCTIONS THOROUGHLY BEFORE INSTALLING OR SERVICING THIS EQUIPMENT.

DANGER

If you smell gas:

- Shut off gas to the appliance.
- Extinguish any open flame.
- If odor continues, keep away from the appliance and immediately call your gas supplier or your fire department.

SAFETY PRECAUTIONS

Before installing and operating this equipment, be sure everyone involved in its operation is fully trained and aware of precautions. Accidents and problems can be caused by failure to follow fundamental rules and precautions.

The following symbols, found throughout this manual, alert you to potentially dangerous conditions to the operator, service personnel, or to the equipment.



This symbol warns of immediate hazards which will result in severe injury or death.



This symbol refers to a potential hazard or unsafe practice which could result in injury or death.



This symbol refers to a potential hazard or unsafe practice which could result in injury, product damage, or property damage.



This symbol refers to information that needs special attention or must be fully understood, even though not dangerous.

WARNING **FIRE HAZARD** **FOR YOUR SAFETY**

Do not store or use gasoline or other flammable vapors and liquids in the vicinity of this or any other appliance.

Keep area around appliances free and clear of combustibles.

Purchaser of equipment must post in a prominent location detailed instructions to be followed in the event the operator smells gas. Obtain the instructions from the local gas supplier.

WARNING

Electrical Grounding This appliance is equipped with a three-prong (grounding) plug for your protection against shock hazard and should be plugged directly into a properly grounded three-prong receptacle. And do not cut or remove the grounding prong from the plug.

WARNING

Asphyxiation can result from improper ventilation. Do not obstruct the flow of combustion and Ventilation air to and from your cooking equipment.

NOTICE

Be sure this Operator's Manual and important papers are given to the proper authority to retain for future reference.

NOTICE

This product is intended for commercial use only. NOT FOR HOUSEHOLD USE.

TABLE OF CONTENTS

Congratulations! You have purchased one of the finest pieces of heavy-duty commercial cooking equipment.

You will find that your new equipment, has been designed and manufactured to meet the toughest standards in the industry. Each piece of equipment is carefully engineered and designs are verified through laboratory tests and field installations. With proper care and field maintenance, you will experience years of reliable, trouble-free operation. **For best results, read this manual carefully.**

RETAIN THIS MANUAL FOR FUTURE REFERENCE.

Table of Contents

- Specifications 4
- Installation 8
- Operation 13
- Cooking Hints 14
- Cleaning 17
- Adjustments 19
- Troubleshooting 22
- Parts 26
- Replacing Oven lamp 30
- Natural to LP gas conversion Procedure 31

Read these instructions carefully before attempting installation. Installation and initial startup should be performed by a qualified installer. Unless the installation instructions for this product are followed by a qualified service technician (a person experienced in and knowledgeable with the installation of commercial gas) then the terms and conditions on the Manufacturer's Limited Warranty will be rendered void and no warranty of any kind shall apply.

SPECIFICATIONS

NOTICE

Local codes regarding installation vary greatly from one area to another. The National Fire Protection Association, Inc. states in its NFPA 96 latest edition that local codes are the “authority having jurisdiction” when it comes to installation requirements for equipment. Therefore, installations should comply with all local codes.

Producer reserves the right to change specifications and product design without notice. Such revisions do not entitle the buyer to corresponding changes, additions, or replacements for previously purchased equipment.

This product is intended for commercial use only, not for household use.

The installation must conform with local codes, or in the absence of local codes, with the *National Fuel Gas Code, ANSI Z223.1, Natural Gas Installation Code, CAN/CGA-B149.1*, or the *Propane Installation Code CAN/CGA-B149.2*, as applicable, including:

1. The appliance and its individual shutoff valve must be disconnected from the gas supply piping system during any pressure testing of that system at test pressures in excess of 1/2 psi (3.45 kPa).
2. The appliance must be isolated from the gas supply piping system by closing its individual manual shutoff valve during any pressure testing of the gas supply piping system at test pressures equal to or less than 1/2 psi (3.45 kPa).

ELECTRICITY SUPPLY

Convection ovens require connection to a supply of electricity. The appliance, when installed, must be electrically grounded in accordance with local codes, or in the absence of local codes, with the *National Electrical Code, ANSI/NFPA 70*, or the *Canadian Electrical Code, CSA C22.2*, as applicable. An electrical diagram is located on the side of the control panel assembly (see drawing on page 20). Electrical diagrams can also be found in this manual beginning on page 21.

| Power Option | Power | # of Ovens | Maximum Amps |
|--------------|--------------------------------|-------------|--------------|
| 120/60/1 | 120 Volts, 60 Hz, Single Phase | Single-Deck | 9.3 |

Single-deck ovens will have one 120 volt single phase power cord.

GAS SUPPLY

The serial plate indicates the type of gas the unit is equipped to burn. All equipment is adjusted at the factory. Check type of gas on serial plate.

These models are design-certified for operation on natural or propane gases. For natural gas, the regulator is set to deliver a 4" W.C. pressure to the manifold. For propane gas, it is set to deliver 10" W.C.

If applicable, the vent line from the gas appliance pressure regulator shall be installed to the outdoors in accordance with local codes, or in the absence of local codes, with the *National Fuel Gas Code, ANSI Z223.1, Natural Gas Installation Code, CAN/CGA-B149.1*, or the *Propane Installation Code CAN/CGA-B149.2*, as applicable.

This appliance should be connected ONLY to the type of gas for which it is equipped.

A 3/4" NPT line is provided at the rear for the gas connection. An adequate gas supply is imperative. Undersized or low pressure lines will restrict the volume of gas required for satisfactory performance. Fluctuations of more than 25% on natural gas or 10% on propane gas will create problems and affect burner operating characteristics.

An adequate gas supply line to the unit should be no smaller than the inside diameter of the pipe from the unit to which it is connected.

Purge the supply line to clean out dust, dirt, or other foreign matter before connecting the line to the unit.

All pipe joints and connections must be tested thoroughly for gas leaks. Use only soapy water for testing on all gases. NEVER use an open flame to check for gas leaks. All connections must be checked for leaks after the unit has been put into operation. Test pressure should not exceed 1/4" W.C.

| Model | # of Ovens | Oven Depth | Type of Gas | Orifice Size | # of Burners | Total BTU |
|-----------------|-------------------|-------------------|--------------------|---------------------|---------------------|------------------|
| Convection oven | Single-Deck | 22.5" | Natural Gas | 45 | 3 @ 18,000 BTU | 54,000 |
| | | | LP | 55 | | |

THIS APPLIANCE IS EQUIPPED FOR NATURAL GAS.

All oven shipped for Natural Gas.

Each oven is shipped with an LP Gas Conversion kit,

For conversion to LP gas see the conversion instruction (Page.29).

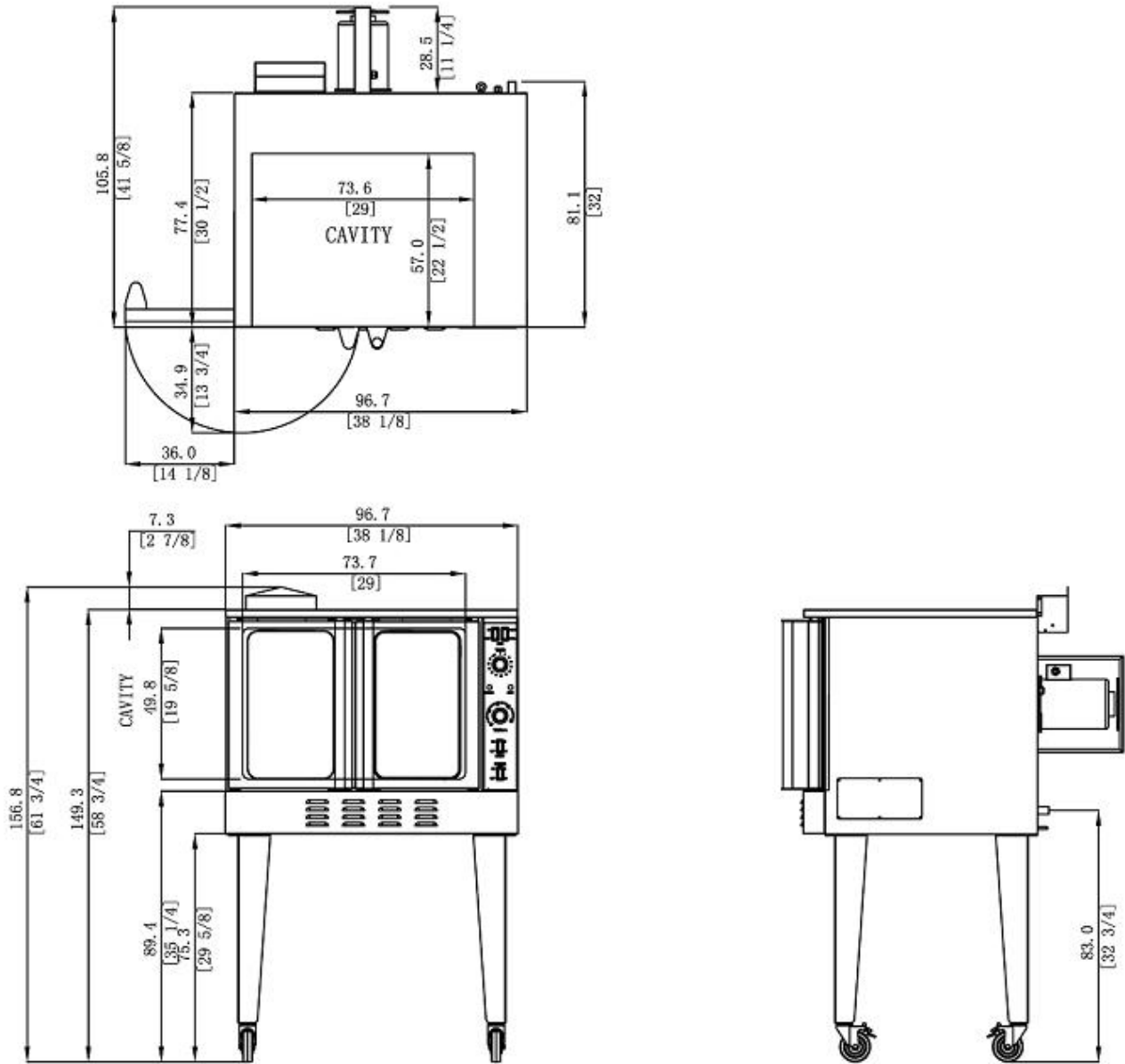

Single Oven with Leg and Caster Kit

| Model | Overall Dimensions | Oven Interior | Rack Clearance | Shipping Crate(s) |
|--------|---|--|--------------------------------------|---|
| SINGLE | 38.12"W x 44.37"D x 60"H (97 cm x 113 cm x 152 cm) | 29"L x 22.5"W x 19.37"H (74 cm x 57 cm x 50 cm) | 28"Width, 21"Depth (72 cm, 54 cm) | 45.27"L x 49.21"W x 38.98"H, 50 cu ft., 512 lbs. (115cm x 125cm x 99 cm, 1.42 cu m., 232 kgs.) |

Order Oven Body quantity and leg configuration as desired:
 XXXXXXXX - Convection Oven Body
 XXXXXXXX - Single Oven Leg with Caster Kit

| LEG OR STACKING KITS | Shipping Carton |
|-----------------------------------|---|
| SINGLE OVEN LEG AND CASTER KIT | 29.92" L x 18.11"W x 8.66"H, 2.7 cu ft., 40.8 lbs. (76 cm x 46 cm x 22 cm, 0.077 cu m., 18.5 kgs.) |

MINIMUM CLEARANCES

WARNING

There must be adequate clearance between the left side of the ovens and combustible construction.

| | Minimum Clearance from Combustible | Minimum Clearance from Non-Combustible |
|------------|---------------------------------------|---|
| Back | 6" | 6" |
| Right Side | 6" | 0" |
| Left Side | 6" | 0" |

Adequate clearance must be provided in the aisle to allow the doors to open sufficiently to permit the removal of the racks and for serviceability.

Although no clearance is required behind the motor on the rear of the oven, care must be taken to provide adequate air circulation to prevent the motor from overheating.

Do not locate the oven adjacent to any high heat or grease-producing piece of equipment, such as a range top, griddle, fryer, etc., that could allow radiant heat to raise the exterior temperature of the oven above 130°F (54°C). **DO NOT MOUNT ABOVE OTHER COOKING EQUIPMENT.**

VENTILATION

WARNING

Improper ventilation can result in personal injury or death. Ventilation which fails to properly remove flue products can cause headaches, drowsiness, nausea, or could result in death.

All units must be installed in such a manner that the flow of combustion and ventilation air are not obstructed. Provisions for adequate air supply must be provided. Do not obstruct the front or rear of the unit as combustion air enters through these areas.

Be sure to inspect and clean the ventilation system according to the ventilation equipment manufacturer's instructions.

NOTICE

Proper ventilation is the owner's responsibility. Any problem due to improper ventilation will not be covered by the warranty.

If a ventilation canopy is used, it is recommended that a canopy extend 6" past the appliance and that the bottom edge be located 6'6" from the floor. Filters should be installed at an angle of 45° or more from the horizontal. This position prevents dripping grease and facilitates collecting the run-off grease in a drip pan, unusually installed with a filter.

If an exhaust fan is used, it should be installed at least 2" above the flue opening at the top of the unit. A strong exhaust fan tends to create a vacuum in the room and may interfere with burner performance. Fresh air openings approximately equal to the fan area will relieve such a vacuum. In case of unsatisfactory performance on any appliance, check the appliance with the exhaust fan in the "OFF" position. Do this only long enough to check equipment performance. Then turn the exhaust fan back on and let it run to remove any exhaust that may have accumulated during the test.

If the oven flue is connected directly to an outside flue, a CSA International design certified down draft diverter must be installed at the flue outlet of the oven and connected to the outside flue.

INSTALLATION

NOTICE

These installation procedures must be followed by qualified personnel or warranty will be void.

Local codes regarding installation vary greatly from one area to another. The National Fire Protection Association, Inc. states in its NFPA 96 latest edition that local codes are the “authority having jurisdiction” when it comes to installation requirements for equipment. Therefore, installations should comply with all local codes.

The installation must conform with local codes, or in the absence of local codes, with the *National Fuel Gas Code, ANSI Z223.1, Natural Gas Installation Code, CAN/CGA-B149.1*, or the *Propane Installation Code CAN/CGA-B149.2*, as applicable, including:

1. The appliance and its individual shutoff valve must be disconnected from the gas supply piping system during any pressure testing of that system at test pressures in excess of 1/2 psi (3.45 kPa).
2. The appliance must be isolated from the gas supply piping system by closing its individual manual shutoff valve during any pressure testing of the gas supply piping system at test pressures equal to or less than 1/2 psi (3.45 kPa).

Step 1: Unpacking

IMMEDIATELY INSPECT FOR SHIPPING DAMAGE

All containers should be examined for damage before and during unloading. The freight carrier has assumed responsibility for its safe transit and delivery. If damaged equipment is received, either apparent or concealed, a claim must be made with the delivering carrier.

Apparent damage or loss must be noted on the freight bill at the time of delivery. The freight bill must then be signed by the carrier representative (Driver). If the bill is not signed, the carrier may refuse the claim. The carrier can supply the necessary forms.

A request for inspection must be made to the carrier within 5 days if there is concealed damage or loss that is not apparent until after the equipment is uncrated. The carrier should arrange an inspection. Be certain to hold all contents plus all packing material.

1. Cut banding straps and remove packing material.
2. Cut banding strap holding oven to wooden skid.

Step 2: Installation of Legs on Single-Deck Ovens (For Stacking kit, refer to instructions included with kit)

1. Raise oven sufficiently to allow clearance for the legs to be attached. Use of a lift truck or other mechanical lifting means is recommended. For safety, “shore up” and support the oven with an adequate blocking arrangement strong enough to support the load. (If it is absolutely necessary to rest the oven on its side, rest it on its left side.)
2. Attach the legs to the bottom corners of the oven using the provided machine screws and lock washers. Each leg is secured by 3 screws. The mounting holes are pre-drilled and threaded.
3. Lower the oven gently onto a level surface. Never drop or allow the oven to fall.
4. Make sure that the oven is level.
5. Install required cable restraint connecting oven to wall.

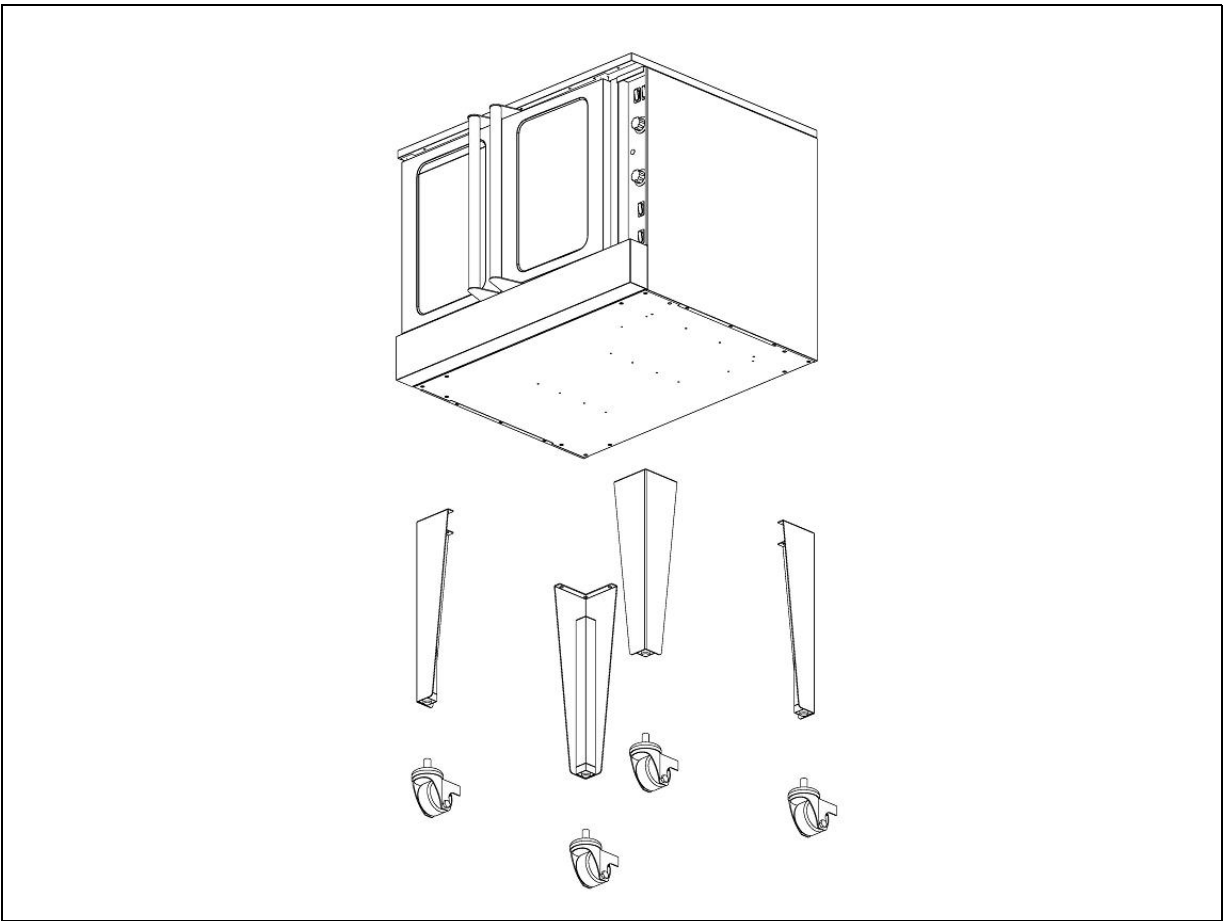

Step 3: Installation of Restraint (Only for Ovens with Casters)

NOTICE

When this appliance is installed with casters, it must be installed with the caster supplied, a connector complying with either ANSI Z21.69 or CAN/CGA-6.16 and a quick-disconnect device complying with either ANSI Z21.41 or CAN1-6.9. It must be installed with a restraining means to guard against transmission of strain to the connector, as specified in the appliance manufacturer's installation instructions.

WARNING

To avoid accidental gas disconnection and potential explosion:

If disconnection of this restraint is necessary to move the appliance for cleaning, etc., reconnect it when the appliance is moved to its originally installed position.

Step 4: Connect Electricity



WARNING **ELECTRIC GROUNDING INSTRUCTIONS**

This appliance (120V ovens only) is equipped with a three-prong (grounding) plug for your protection against shock hazard and should be plugged directly into a properly grounded three-prong receptacle. Do not cut or remove the grounding prong from this plug.

NOTICE

This appliance, when installed, must be electrically grounded in accordance with local codes, or in the absence of local codes, with the *National Electrical Code, ANSI/NFPA 70* or the *Canadian Electrical Code, CSA C22.2*, as applicable.

Wiring diagrams are located on the side of the control panel assembly, as well as in this manual (beginning on page 21). Be sure that the input voltage and phase match the requirements shown on the serial plate, which is located inside the lower front panel.

Ovens ordered to operate on **120V** power have a three-wire cord. Single-oven units require a 15 ampere supply.

Step 5: Connect Gas Supply

NOTICE

The installation must conform with local codes, or in the absence of local codes, with the *National Fuel Gas Code, ANSI Z223.1, Natural Gas Installation Code, CAN/CGA-B149.1*, or the *Propane Installation Code CAN/CGA-B149.2*, as applicable, including:

1. The appliance and its individual shutoff valve must be disconnected from the gas supply piping system during any pressure testing of that system at test pressures in excess of 1/2 psi (3.45 kPa).
2. The appliance must be isolated from the gas supply piping system by closing its individual manual shutoff valve during any pressure testing of the gas supply piping system at test pressures equal to or less than 1/2 psi (3.45 kPa).

A 3/4" NPT line is provided at the rear for the gas connection.

If this equipment is being installed at over 2,000 feet altitude and that information was not specified when ordered, contact the appropriate authorized Service Representative or the Service Department. Failure to install with proper orifice sizing will result in poor performance and may void the warranty.

The serial plate is located inside the front lower panel. It indicates the type of gas the unit is equipped to burn. All equipment is adjusted at the factory. Check type of gas on serial plate.

These models are design-certified for operation on natural or propane gases. For natural gas, the regulator is set to deliver a 3.5" W.C. pressure to the manifold. For propane gas, it is set to deliver 11" W.C.

This appliance should be connected **ONLY** to the type of gas for which it is equipped. The inlet pressure before the regulator should be 6-10" W.C. for natural gas or 11-14" W.C. for LP gas.

An adequate gas supply is imperative. Undersized or low pressure lines will restrict the volume of gas required for satisfactory performance. Fluctuations of more than 25% on natural gas or 10% on propane gas will create problems and affect burner operating characteristics.

An adequate gas supply line to the unit should be no smaller than the I.D. of the pipe from the unit to which it is connected.

Purge the supply line to clean out dust, dirt, or other foreign matter before connecting the line to the unit.



CAUTION

ALL PIPE JOINTS AND CONNECTIONS MUST BE TESTED THOROUGHLY FOR GAS LEAKS. USE ONLY SOAPY WATER FOR TESTING ON ALL GASES. NEVER USE AN OPEN FLAME TO CHECK FOR GAS LEAKS. ALL CONNECTIONS MUST BE CHECKED FOR LEAKS AFTER THE UNIT HAS BEEN PUT INTO OPERATION. TEST PRESSURE SHOULD NOT EXCEED 1/4" W.C.

Step 6: Check the Installation

1. Check that all screws and bolts are tightened.
2. Move the oven into the position at which it will be operated.
3. Check that the oven is level. If not, adjust the legs.
4. Check that the appropriate clearances are satisfied (see page 7)

Control Panel

Fan Speed

Use to select fan speed (HI or LOW). The appropriate speed is determined by the type of food being cooked.

Cook Timer

Turn knob to set a time duration. An alarm will sound when the timer runs out. The timer is a reminder to the user; **the timer does not control the oven**

Power on Light

Power Switch

Switch ON to use the oven, switch OFF when done using the oven.

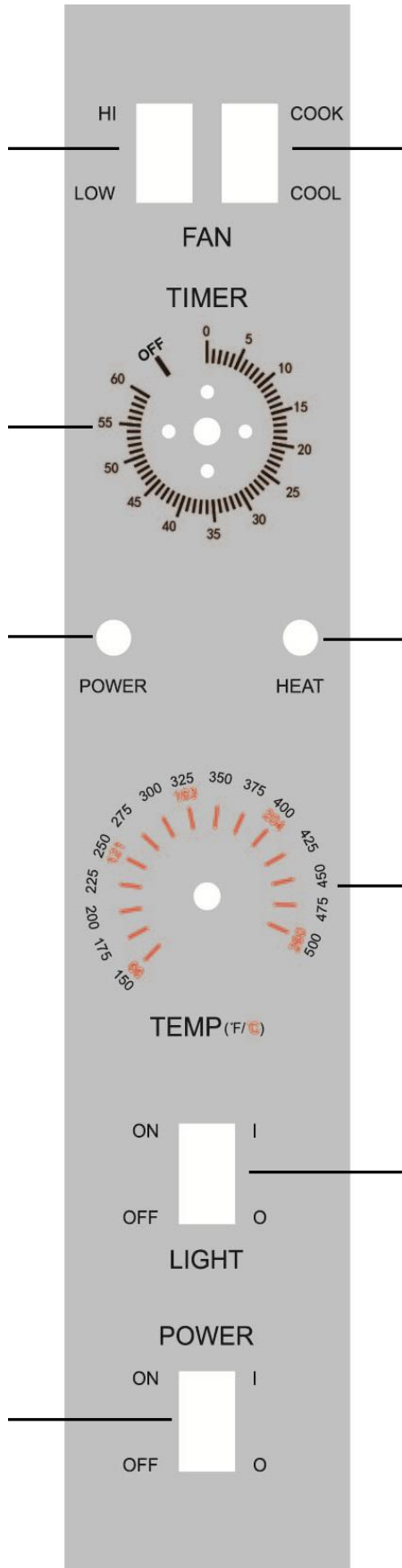

Fan Mode

In COOK mode, the fan runs continuously except when the doors are open. The fan does NOT cycle with the operation of the burners. In COOL mode, the fan runs continuously even if the doors are open. Since the burners will not operate if the oven doors are open, to rapidly cool the oven after cooking is completed, open the doors and switch the fan mode to COOL.

Heat-On Indicator

Indicator is lit when the burners are operating.

Cook Temperature Control

Turn knob to select desired cooking temperature. The Heat On indicator will go out when the oven reaches the set temperature, and will cycle on and off as the burners operate to maintain the set cooking temperature.

Oven Interior Light Switch

On ovens equipped with an oven interior light, press to turn on the light. The light remains on for as long as the switch is held.

OPERATION



DANGER EXPLOSION HAZARD

In the event a gas odor is detected, shut down equipment at the main shut off valve. Immediately call the emergency phone number of your gas supplier.



CAUTION

To eliminate gas build up which could result in an explosion, in the event of main burner ignition failure a five minute purge period must be observed prior to re-establishing ignition source.

NOTICE

For an appliance equipped with a convection oven, no attempt should be made to operate oven during a power failure.

LIGHTING, RELIGHTING, AND SHUTDOWN INSTRUCTIONS

To light the oven, just switch the power switch at the bottom of the control panel to the “ON” position. (The oven is equipped with a direct hot surface ignition system. There is no pilot to light.)

If the burners fail to ignite within four seconds, the oven will automatically shut off the gas, wait five minutes to allow the gas that was released to dissipate, and try to light the burners again. If the burners still fail to ignite after three such attempts, the oven will stop trying, even though the power switch is in the “ON” position. To continue to attempt to light the burners, turn the power switch “OFF” and then “ON” again.

To shutdown the oven, switch the power switch to the “OFF” position.

OPERATING THE CONTROLS

A convection oven is a different type of oven that offers many features and advantages to the food service operation. The additional capabilities and features of the oven require some learning. However, the operation of the oven is not difficult to understand or control once you have some practice.

Operation of STANDARD Models

Models with Standard Controls operate much like a standard oven: you turn the oven ON and select a cooking temperature. Two additional controls are used to control the fan (as described below).

The timer is a reminder to you of when to remove food from the oven. **The timer does NOT control the temperature of the oven.**

To cook, do the following:

1. Turn the oven ON using the Power Switch at the bottom of the control panel.
2. Select the desired fan speed using the Fan Speed switch. The appropriate fan speed (HI or LOW) depends on the type of food being cooked.
3. Switch the Fan Mode switch to COOK. The fan will run continuously when the oven doors are closed (the fan does not cycle on and off with the burners). (If this switch is set to COOL the only difference is that the fan will continue to run when the oven doors are open.)
4. Set the cooking temperature by turning the Cook Temperature Control until the indicator mark on the knob is pointed to the desired cooking temperature. The Heat On indicator will light when the burners are on, and will remain on while the oven preheats.

5. Wait until the Heat On indicator has come on and gone out three times. At that time the oven will have reached the set cooking temperature.
6. Open the oven doors, load the product into the oven, and close the doors.
7. You can use the Cook Timer as a reminder of when to remove the load from the oven. If so desired, turn the Cook Timer knob until the indicator mark points to the desired cooking time (up to 55 minutes). The timer knob will rotate counterclockwise as the timer runs down, indicating how much time remains. You can turn the knob while cooking to increase or decrease the remaining time. When the timer runs out, a buzzer will sound for a short time, then turn itself off. (To immediately silence the buzzer, turn the Cook Timer knob to the OFF position.) The timer is a reminder to you; **the timer does not control the oven.** If you open the oven doors, the burners and fan will shut off until the doors are closed. However, the timer will continue running even if the doors are open.
To turn on the interior oven lights, use the switch located at the bottom of the control panel.
8. When the load has finished cooking, you can rapidly cool the load by opening the oven doors (which will shut off the burners) and switching the Fan Mode to COOL (which will cause the fan to run even though the doors are open). For the most rapid cooling, also switch the Fan Speed switch to HI.
9. When you are done cooking, turn the Cook Temperature control to the lowest setting (fully counterclockwise) and switch the Power Switch to OFF.

COOKING HINTS

In a convection oven, the fan-blown circulating air strips away this insulating layer allowing the heat to penetrate faster for quicker baking and roasting. Hence, in a convection oven cooking procedures and techniques may require some modification for successful results. As a general rule, the cooking time will be shorter and the cooking temperature will be 25°F to 75°F lower than those called for in recipes for a standard oven.

TIME & TEMPERATURE

Time and temperature are important. The “Guide to Times and Temperatures” later in this section is a starting point. The actual best cooking time and temperature will depend on such factors as size of load and mixture of recipe (particularly moisture). Once an appropriate time and temperature has been established for a particular product and load, you will find the result of succeeding loads to be similar.

OVERLOADING

Do NOT overload the oven. The size of the load that can be cooked satisfactorily depends largely on the particular product. As a rule, five racks can be successfully used for shallow cakes, cookies, pies, etc. For deeper cakes (such as angel food), use only three racks because of the size of the pan and the space required for rising. For hamburger patties, fish sticks, cheese sandwiches, etc., a full complement of racks and pans is usually satisfactory.

HELPFUL SUGGESTIONS

Here are some suggestions that will assist in getting the best possible performance from a convection oven:

- Pre-heat the oven thoroughly before use.
- When re-thermalizing frozen products, pre-heat the oven to 50°F higher than the planned cooking temperature. After loading, reduce the temperature setting to the appropriate cooking temperature.
- Space the racks and pans as evenly as possible to allow air circulation.
- Center the load on the racks to allow for proper air circulation around the sides. Do not cover the racks completely with pans.
- Do not use a deep pan for shallow cakes or cookies, etc. Air circulation across the surface of the product is essential.

 **WARNING**

THE USE OF ALUMINUM FOIL CAN CAUSE HEAT DISTRIBUTION PROBLEMS IN OVENS. EXTREME CARE MUST BE USED WHEN PLACING ALUMINUM FOIL IN THE OVEN TO ENSURE THAT IT DOES NOT BLOCK OR CHANGE THE AIR FLOW. THE USE OF ALUMINUM FOIL MAY VOID THE PRODUCT WARRANTY IF ITS USE IS ASCERTAINED TO BE A PROBLEM.

HOLDING FOOD BEFORE SERVING

Any food item prepared in steam table pans can be held until being served by setting the Hold thermostat to 160°F. Examples include stuffed pork chops, oysters Rockefeller, and any vegetable entree.

COOKING PROBLEMS AND SOLUTIONS

| If... | then... |
|---|---|
| Cakes are dark on the sides and not done in the | lower oven temperature. |
| Cake edges are too brown... | reduce number of pans or lower oven temperature. |
| Cakes have a light outer color... | raise temperature. |
| Cakes settle slightly in the center... | bake longer or raise oven temperature slightly. Do not open doors except to load or unload |
| Cakes ripple... | do not overload pans or use batter that is too thin. |
| Cakes are too coarse... | lower oven temperature. |
| Pies have uneven color... | reduce number of pies per rack or eliminate use of |
| Brown sugar topping or meringue blows off... | after oven is preheated, turn off oven and put product in oven until topping sets, then turn oven |
| Rolls have uneven color... | reduce number or size of pans. |
| Meats are browned and not done in center... | lower oven temperature and roast longer. |
| Meats are well done and not browned... | raise temperature. Limit amount of moisture. |
| Meats develop hard crust... | reduce temperature or place pan of water in oven. |
| Excessive meat shrinkage occurs... | lower oven temperature. |

GUIDE TO TIMES AND TEMPERATURES

As a guide, set oven temperatures 25°F to 75°F lower than called for in recipes for non-convection ovens, (i.e., range or deck ovens).

Time and temperature will vary depending upon load, mix, size, portion, initial temperature of food, and other factors. Use the following chart as a starting point to develop your own cooking techniques. Rack loading and position may affect results. Experimentation may be necessary to suit individual requirements.

| | Cooking Time | Temperature | Number of Racks |
|--------------------------------|---------------------|--------------------|------------------------|
| Meat and Fish | | | |
| Top Round, 18-20 lbs. (medium) | 5 hours | 275°F | 1 |

| | | | |
|-----------------------|---------------|-------|---|
| Prime Ribs (rare) | 4 hours | 225°F | 1 |
| Burger Patties, 4 oz. | 10 min. | 350°F | 5 |
| Fish Cakes | 10-12 min. | 375°F | 5 |
| Turkey, 10-12 lbs. | 3 hr. 20 min. | 225°F | 1 |

Cooking Time Temperature Number of Racks

Baked Goods

| | | | |
|----------------------------|------------|-------|---|
| Bread, 2 lb. loaf | 35 min. | 375°F | 3 |
| Biscuits | 5-10 min. | 400°F | 5 |
| Cornbread | 18 min. | 400°F | 5 |
| French Bread | 10 min. | 375°F | 5 |
| Sheet Cake | 18-20 min. | 300°F | 5 |
| Cream Puffs | 20 min. | 375°F | 5 |
| Brown & Serve Rolls | 6 min. | 400°F | 5 |
| Ginger Bread | 18 min. | 300°F | 5 |
| Yeast Rolls, sheet pan | 16-18 min. | 325°F | 5 |
| Pineapple Upside Down Cake | 25-30 min. | 325°F | 5 |
| Apple Turnovers | 15-18 min. | 350°F | 5 |
| Fruit Cobbler | 22-25 min. | 375°F | 5 |
| Brownies | 15 min. | 350°F | 5 |
| Danish Pastry | 12 min. | 325°F | 5 |
| Pie Shells | 12 min. | 350°F | 5 |
| Fresh Fruit Pies | 25-30 min. | 350°F | 5 |
| Pumpkin Pies | 25-30 min. | 275°F | 5 |
| Fresh Apple Pies | 35 min. | 375°F | 5 |
| Frozen Berry Pies | 40 min. | 375°F | 5 |
| Frozen Fruit Pies | 45 min. | 375°F | 5 |

Potatoes

| | | | |
|-------------------------|------------|-------|---|
| Baked Potatoes, 10 oz. | 50-55 min. | 450°F | 5 |
| Baked Potatoes, 6-8 oz. | 40-45 min. | 450°F | 5 |
| Scalloped Potatoes | 35 min. | 325°F | 5 |

Miscellaneous

| | | | |
|---------------------------|---------|-------|---|
| Macaroni and Cheese | 30 min. | 350°F | 5 |
| Stuffed Peppers | 18 min. | 350°F | 5 |
| Toasted Cheese Sandwiches | 8 min. | 375°F | 5 |

CLEANING

Equipment is sturdily constructed of the best materials and is designed to provide durable service when treated with ordinary care. To expect the best performance, your equipment must be maintained in good condition and cleaned daily. Naturally, the periods for this care and cleaning depend on the amount and degree of usage.

Following daily and periodic maintenance procedures will enhance long life for your equipment. Climatic conditions (such as salt air) may require more thorough and frequent cleaning or the life of the equipment could be adversely affected.

The oven interior is finished with a porcelain enamel coating. "Spillovers" should be cleaned from the interior bottom surface as soon as possible to prevent carbonizing and a burnt-on condition. Grease or any residue should be cleaned from interior surfaces as soon as it accumulates.

WARNING

FOR YOUR SAFETY, DISCONNECT THE POWER SUPPLY TO THE APPLIANCE BEFORE CLEANING.

WHEN CLEANING THE BLOWER WHEEL, BE SURE TO HAVE THE POWER SWITCH IN THE "OFF" POSITION.

DAILY CLEANING

1. Turn the power switch to OFF and allow the oven to cool.
2. Remove the oven-interior racks and rack slide frames. (The rack slide frames are readily removable by merely raising to disengage them from their sockets.) Wash the racks and rack slides in a sink with mild detergent and warm water. Dry them thoroughly with a clean cloth.
3. Look to see if any foreign matter has accumulated on the wire grate in front of the fan blower wheel on the wheel itself (which will reduce air circulation). If necessary, remove the rear panel of the oven, which is secured by bolts near each corner. Use a stiff brush to remove accumulations from the blower blades, then wash with soap and water.
4. Wash the interior surfaces with mild detergent and warm water. Rinse with clean water, and dry thoroughly with a clean cloth. For stubborn accumulations, a commercial oven cleaner may be used.
5. Clean the control panel with warm water and mild soap. Never use cleaning solvents with a hydrocarbon base.
6. Wipe the other exterior surfaces with a clean damp cloth. If the exterior surfaces require more thorough cleaning, see "Cleaning Stainless Steel Surfaces" on the next page.
7. Return the rack slides and racks to their appropriate locations inside the oven.
8. LEAVE THE DOOR OPEN AT NIGHT AFTER CLEANING. This allows the oven to dry thoroughly after cleaning and also prolongs the life of the door gasket.

MONTHLY CLEANING

Clean around rear of motor (where the vent screen is located), louvered panels, and primary air holes in the rear of the oven where grease or lint may have accumulated.

SEMI-ANNUAL CLEANING

At least twice a year have your Authorized Service Agency or another qualified service technician clean and adjust the unit for maximum performance.

At least twice a year the oven's venting system should be examined and cleaned.

CLEANING STAINLESS STEEL SURFACES

To remove normal dirt, grease and product residue from stainless steel that operates at LOW temperature, use ordinary soap and water (with or without detergent) applied with a sponge or cloth. Dry thoroughly with a clean cloth.

To remove grease and food splatter, or condensed vapors, that have BAKED on the equipment, apply cleanser to a damp cloth or sponge and rub cleanser on the metal in the direction of the polishing lines on the metal. Rubbing cleanser, as gently as possible, in the direction of the polished lines will not mar the finish of the stainless steel. NEVER RUB WITH A CIRCULAR MOTION. Soil and burnt deposits which do not respond to the above procedure can usually be removed by rubbing the surface with SCOTCH-BRITE scouring pads or STAINLESS scouring pads. DO NOT USE ORDINARY STEEL WOOL, as any particles left on the surface will rust and further spoil the appearance of the finish. NEVER USE A WIRE BRUSH, STEEL SCOURING PADS (EXCEPT STAINLESS), SCRAPER, FILE OR OTHER STEEL TOOLS. Surfaces which are marred collect dirt more rapidly and become more difficult to clean. Marring also increases the possibility of corrosive attack. Refinishing may then be required.

To remove heat tint – Darkened areas sometimes appear on stainless steel surfaces where the area has been subjected to excessive heat. These darkened areas are caused by thickening of the protective surface of the stainless steel and are not harmful. Heat tint can normally be removed by the foregoing, but tint which does not respond to this procedure calls for a vigorous scouring in the direction of the polish lines, using SCOTCH-BRITE scouring pads or a STAINLESS scouring pad in combination with a powered cleanser. Heat tint action may be lessened by not applying, or by reducing heat to equipment during slack periods.

ADJUSTMENTS

WARNING

ADJUSTMENTS AND SERVICE WORK MAY BE PERFORMED ONLY BY A QUALIFIED TECHNICIAN WHO IS EXPERIENCED IN, AND KNOWLEDGEABLE WITH, THE OPERATION OF COMMERCIAL COOKING EQUIPMENT. HOWEVER, TO ASSURE YOUR CONFIDENCE, CONTACT YOUR AUTHORIZED SERVICE AGENCY FOR RELIABLE SERVICE, DEPENDABLE ADVICE OR OTHER ASSISTANCE, AND FOR GENUINE FACTORY PARTS.

NOTICE

Warranty will be void and the manufacturer is relieved of all liability if service work is performed by other than a qualified technician, or if other than genuine replacement parts are installed.

LUBRICATION

Motor lubrication information can be found on permanent label located on motor. Casters are provided with a Zerk fitting for proper lubrication when required.

ADJUSTING GAS PRESSURE REGULATOR

The pressure regulator is factory set at 3.5" W.C. for natural gas and 11" W.C. for propane gas. To check the manifold pressure:

1. Turn all thermostats and burner valves to "OFF" position.
2. Turn main gas valve to entire unit off.
3. Remove valve panels and locate 1/8" plug in manifold.
4. Remove plug and install a fitting appropriate to connect a manometer.
5. Turn on main gas to unit and light pilots.
6. Turn all burners and ovens to full "ON" position and read manometer.
7. If manometer does not read 3.5" W.C. for natural gas, or 11" W.C. for propane gas, adjust regulator (if gas pressure is O.K. go to Step 10).
8. Remove cap from top of regulator.
9. With a screwdriver rotate regulator adjustment screw clockwise to increase, or counterclockwise to decrease, pressure until manometer shows correct reading.
10. Repeat steps 1 and .
11. Remove manometer fitting and replace plug in manifold.
12. Repeat step .
13. Replace valve anels.

ADJUSTING DOOR SWITCH

The door switch detects when the oven doors are open. As adjusted at the factory, when the doors are opened more than 2 to 4 inches, the burners and fan should shut off (unless the fan is switched to “COOL” mode). To adjust the door switch, do the following:

1. Remove lower front panel that covers the door chain mechanism.
2. Close both doors.
3. Check that the door switch cam is operating the door switch.

CAUTION

Do NOT adjust the door switch so that the plunger arm is completely depressed and is hitting the switch body. This could distort the arm and cause the switch to operate poorly.

TEMPERATURE CONTROLLER

Temperature controller is set at the factory and should only be changed or adjust by a qualified service technical.

TROUBLESHOOTING

WARNING

ADJUSTMENTS AND SERVICE WORK MAY BE PERFORMED ONLY BY A QUALIFIED TECHNICIAN WHO IS EXPERIENCED IN, AND KNOWLEDGEABLE WITH, THE OPERATION OF COMMERCIAL COOKING EQUIPMENT. HOWEVER, TO ASSURE YOUR CONFIDENCE, CONTACT YOUR AUTHORIZED SERVICE AGENCY FOR RELIABLE SERVICE, DEPENDABLE ADVICE OR OTHER ASSISTANCE, AND FOR GENUINE FACTORY PARTS.

NOTICE

Warranty will be void and the manufacturer is relieved of all liability if service work is performed by other than a qualified technician, or if other than genuine replacement parts are installed.

In case of problems in operation at initial installation, check type of gas and manifold pressure and compare with information listed on the serial plate. The serial plate is located inside the lower front panel.

PERFORMANCE STANDARD

The typical time for the oven to heat from 75°F to 350°F is 5 to 6 minutes for ovens using natural gas, and 7 to 8 minutes for ovens using propane.

The burners should come on when the actual oven temperature drops to 10°F below the temperature setting.

TROUBLESHOOTING GUIDE

The left column of the following table lists symptoms that indicate a problem, while the center and right columns list the possible causes and appropriate corrective action. Note that the recommendations of this table assume that the wiring connections are good. When checking a component, always check the wiring attached to the component as well.

| Symptom | Possible Cause | Check or Replace |
|--|--|---|
| Oven will not hold correct temperature. | Temperature probe not working. | Resistance across temperature probe leads at room temperature (70°F) should be approximately 1096 ohms. |
| | Temperature control not calling for heat. | When heat is required, there should be continuity between terminals 6 and 7 on temperature control. |
| | Undersized gas supply line | Oven requires 3/4" ID gas line. |
| | Low gas pressure. | Oven requires 4" manifold water column pressure for natural gas, 11" for propane. |
| | Inadequate or improper ventilation. | Check ventilation hood. Verify draw and make up air adjustment. |
| | Out of calibration. | Calibrate according to procedure described on page 40. |
| Hot surface ignitor glows red but burners do not come on when thermostat calls for heat (cooking light is on). | No power to gas valve. | Check for 24V from ignition box to gas valve. |
| | Faulty main gas solenoid. | Replace gas valve. |
| | Faulty ignition module. | Replace ignition module. |
| | Manual shutoff valve closed. | Open all shut-off valve. |
| | Manual valve on gas valve turned off. | Open manual valve on gas valve. |
| | Hot surface ignitor not in front of rear end of burner. | Re-position hot surface ignitor to be in front of rear end of burner. |
| Hot surface ignitor does not glow red. | No power to ignitor. | Check that voltage from ignitor module to ignitor is 120 Volt. |
| | Ignitor broken or cracked. | Should read continuity between leads on ignitor. |
| | No power or ignition module. | Should be 24V from transformer to ignition module. |
| | Check power to transformer. | Should be voltage stamped on serial plate. Check between 3 and 6 on terminal strip. |
| | Check blower motor. Motor should turn when power switch is turned on and temperature control calls for heat. | Motor has centrifugal switch. Motor must be turning before ignition circuit is energized. |
| | Temperature control does not call for heat. | Must read continuity between 6 and 7 on temperature control when calling for heat. |
| | No power out of power switch. | Check that unit power cord is plugged into power supply. Check switch for continuity when switch is closed. |
| First burner next to ignitor lights, but flame will not carry across to other burners. | Burners not aligned. | Check burner carry over wings for proper mating. |
| | Burner and orifice out of alignment. | Orifice must inject gas down center of burner. |
| | Gas pressure to low. | Oven requires 3.5" manifold water column pressure for natural gas, 11" for propane. |
| | Burner orifices clogged. | Make sure burner orifices are clear. |

Table continues on next page.

TROUBLESHOOTING GUIDE (continued)

| Symptom | Possible Cause | Check or Replace |
|--|-----------------------------|--|
| Burners light but go out within a few seconds. (Ignitor will glow approximately 4 seconds. If burner does not ignite, ignition module will try 3 times and then lock out.) | Bad flame switch. | Check in series on micro amps. Minimum is 0.75 amps, no maximum. |
| | Bad gas valve. | Check gas valve. Should be 24 volts from ignition module on wires 46 and 47. |
| Blower motor will not come on. | No incoming electric power. | Check incoming power. |
| | Loose wire connections. | Check wire connections. |
| | Bad contactors. | Contactors pull in and supply power to motor. Verify contactors pulling in. |
| | Motor bad. | If power is being supplied but motor will not turn, replace motor. |

CONTROL PANEL ACCESS

To access the control panel components, remove the screw at the top of the control panel and pull the top of the control panel out and down (see drawing below). A wiring diagram for the oven is located on the side of the control panel assembly.

Accessing Control Panel Components

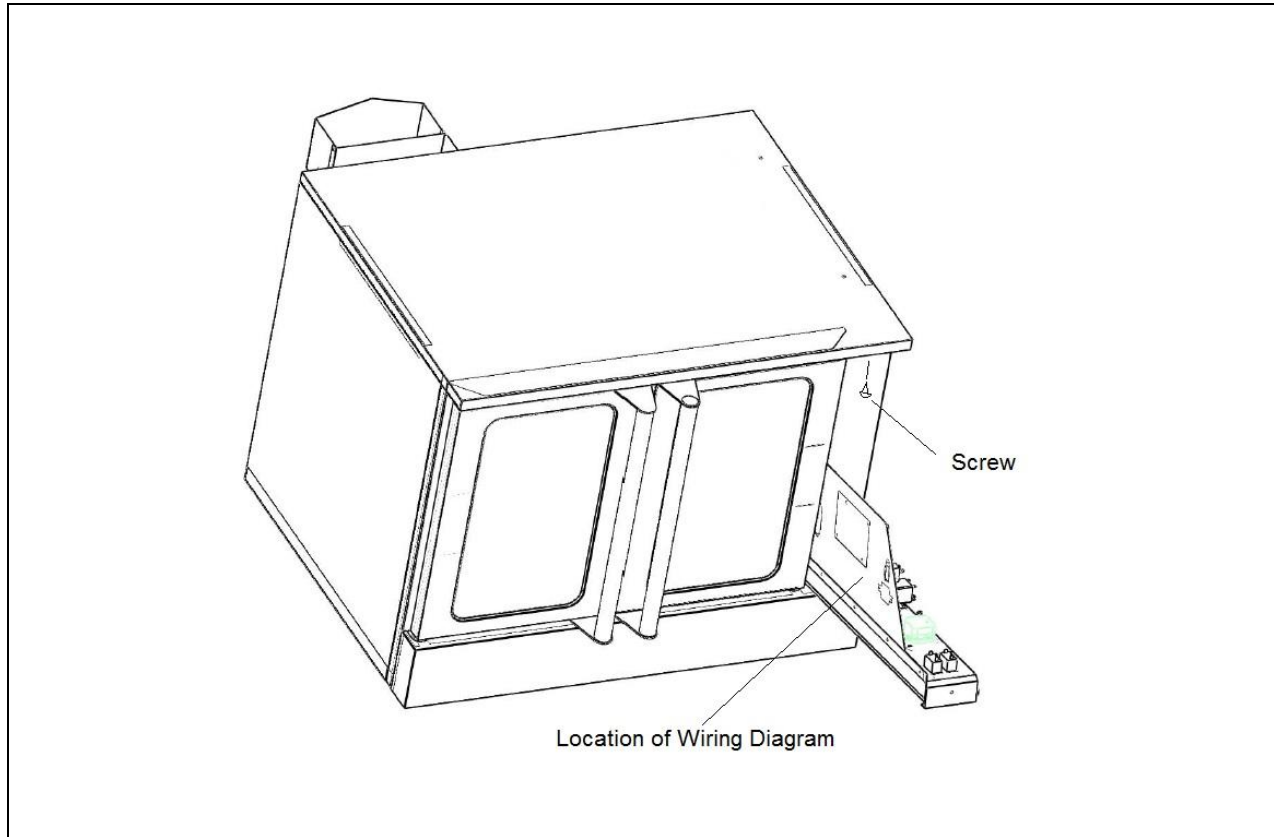

REPLACEMENT

CLEANING OF AIR INTAKE GRATEING AND BLOWER FAN WHEEL

To clean the air intake grating or blower wheel, do the following:

1. Remove racks and rack guides.
2. Clean intake wire grating with wet rag. If necessary to remove, remove (4) small bolts holding grating in place. After cleaning, reinstall wire grating.
3. If fan blower fan wheel is to be cleaned: Loosen (4) bolts holding entire rear panel over blower fan opening . Remove panel.
3. Clean blower wheel with wet rag. (Do not remove blower wheel from motor shaft.)
4. Replace rear panel, insert bolts and tighten. Make sure fan wheel is free of any obstructions.

Electrical Schematic for 120 Volt

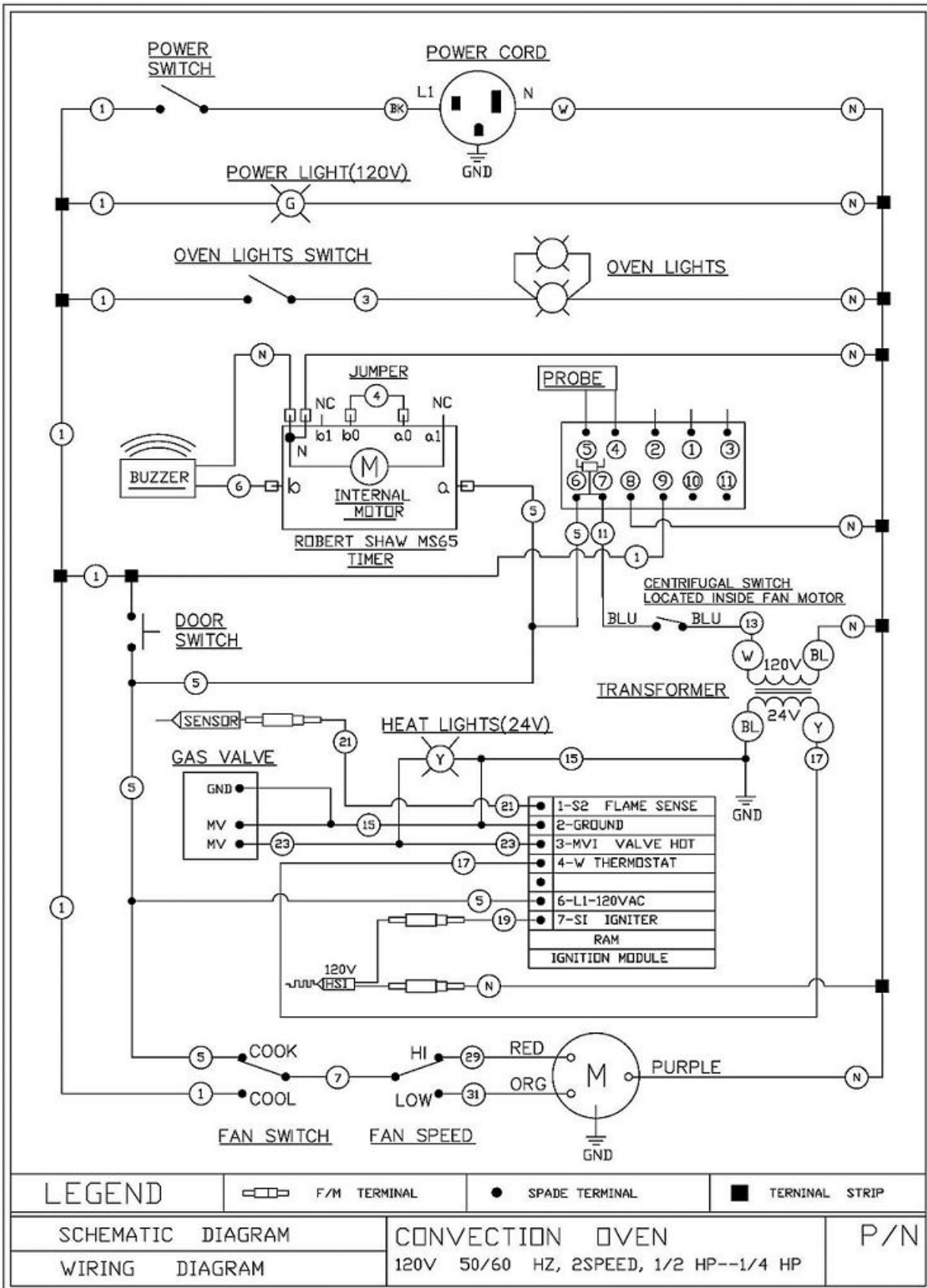

GAS OVEN WIRING DIAGRAM

| NO. | PART NAME | SPECIFICATION |
|-----|---------------------------|---------------------------|
| 1 | TIMER | ROBERT SHAW NS65 |
| 2 | TEMPERATURE CONTROL BOARD | FAST(66A00B305)500°F-120V |
| 3 | POWER LIGHT | 120V |
| 4 | COOK SWITCH | #R13-129C, E67774 |
| 5 | FAN SPEED SWITCH | #R13-129C, E67774 |
| 6 | OVEN LIGHT SWITCH | #R13-129C, E67774 |
| 7 | POWER SWITCH | #R13-129C, E67774 |
| 8 | SHUT DOWN SWITCH | B |
| 9 | DOOR SWITCH | B |
| 10 | TRANSFORMER | 40110F-120V-24V, 40AMP |
| 11 | HSI 120V | Invensys(41-604)120V |
| 12 | SENSOR | Invensys(10-760)120V |
| 13 | HEAT LIGHT | 24V |
| 14 | IGNITION MODULE | FENVAL(35655205-001) |
| 15 | MOTOR | YUN5646E2,120V,1/2-1/4 HP |
| 16 | GAS VALVE | Robert Shaw 7200P/ER |
| 17 | OVEN LIGHTS | 81X65mm,110V,40W |
| 18 | POWER LIGHT | ROBERT SHAW NS65 |
| 19 | PROBE | PT1000 |
| 20 | BUZZER | |
| 21 | LINE CORD | |

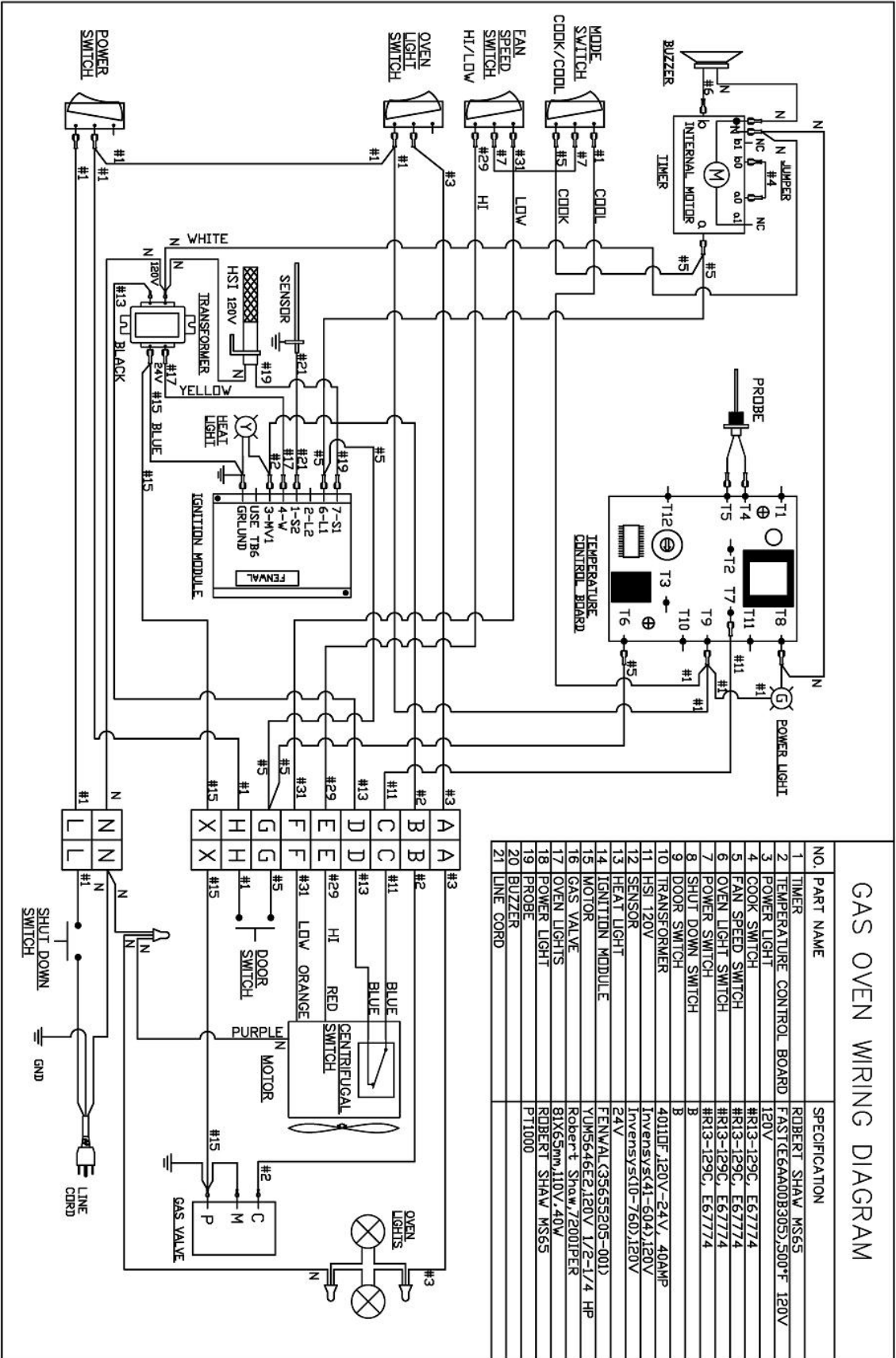

PARTS

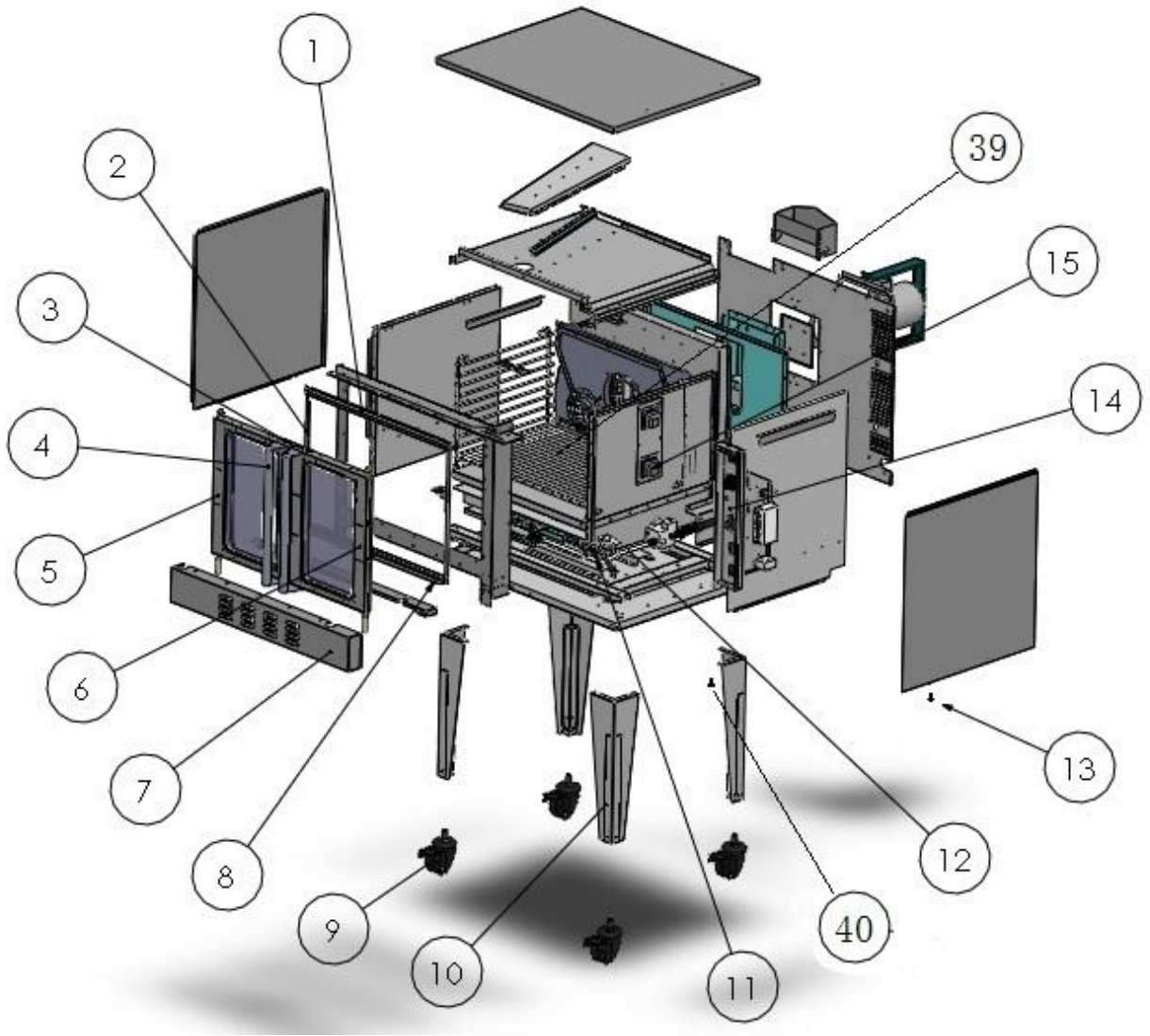

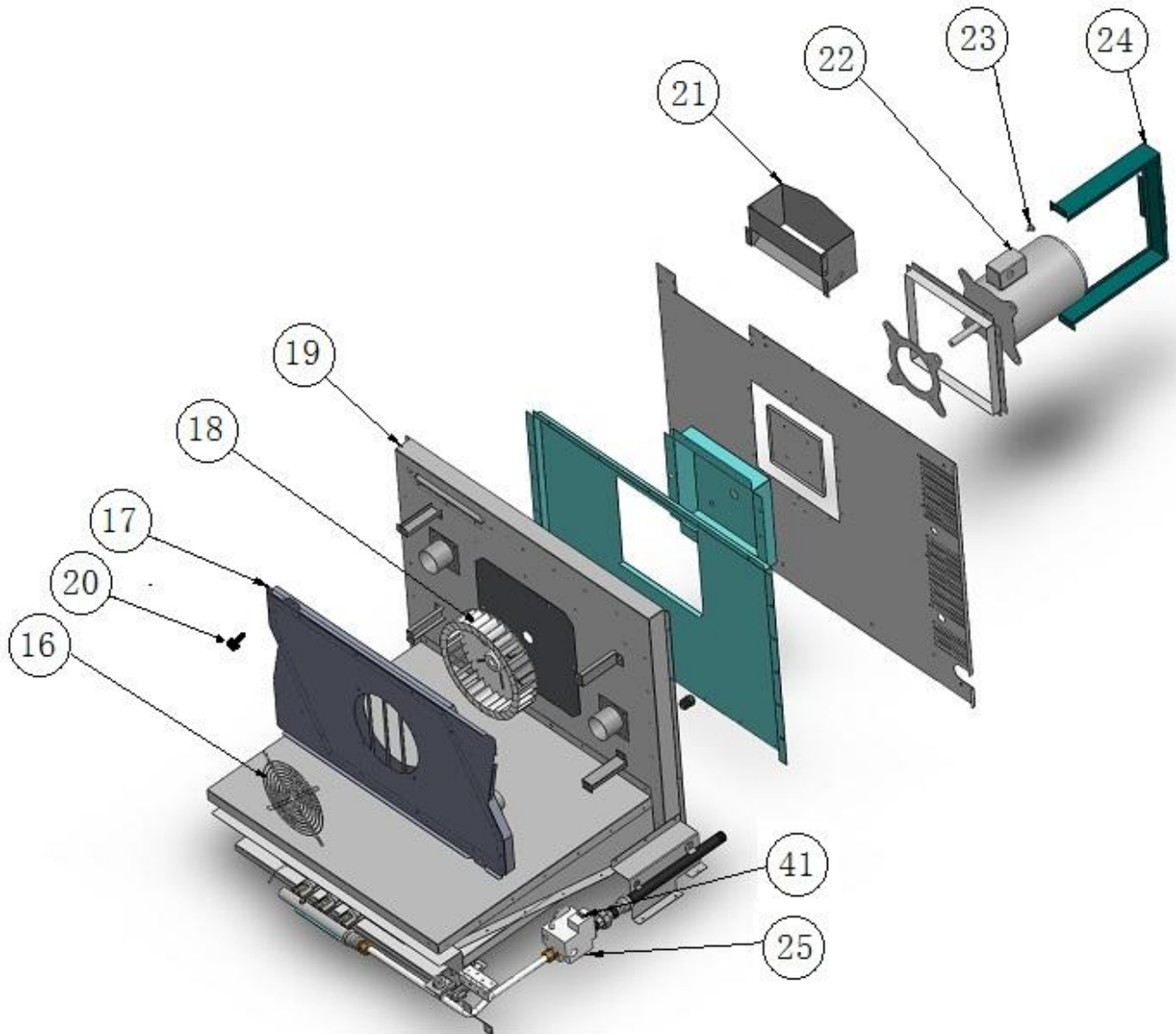

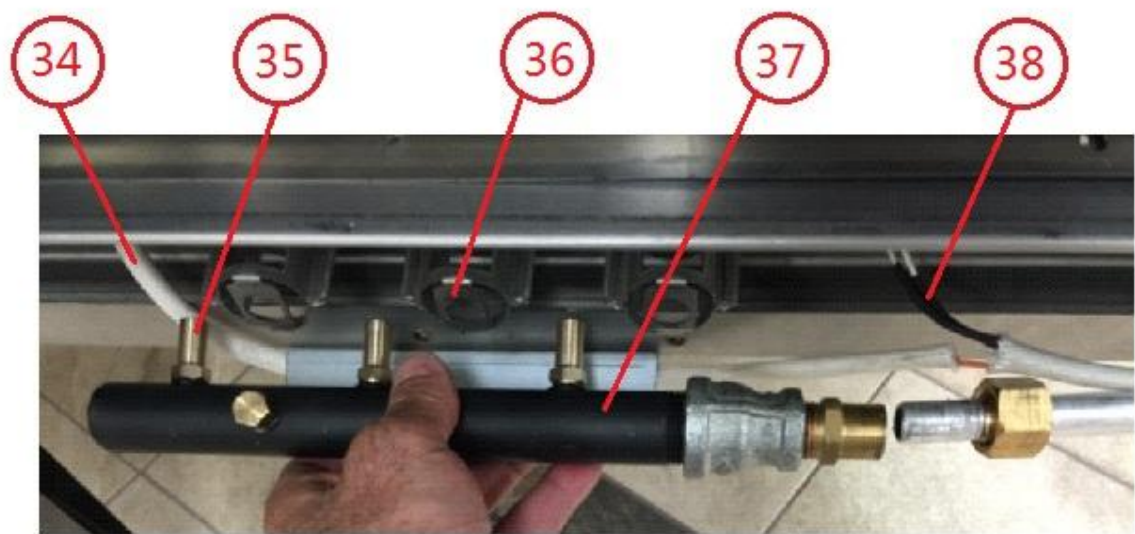
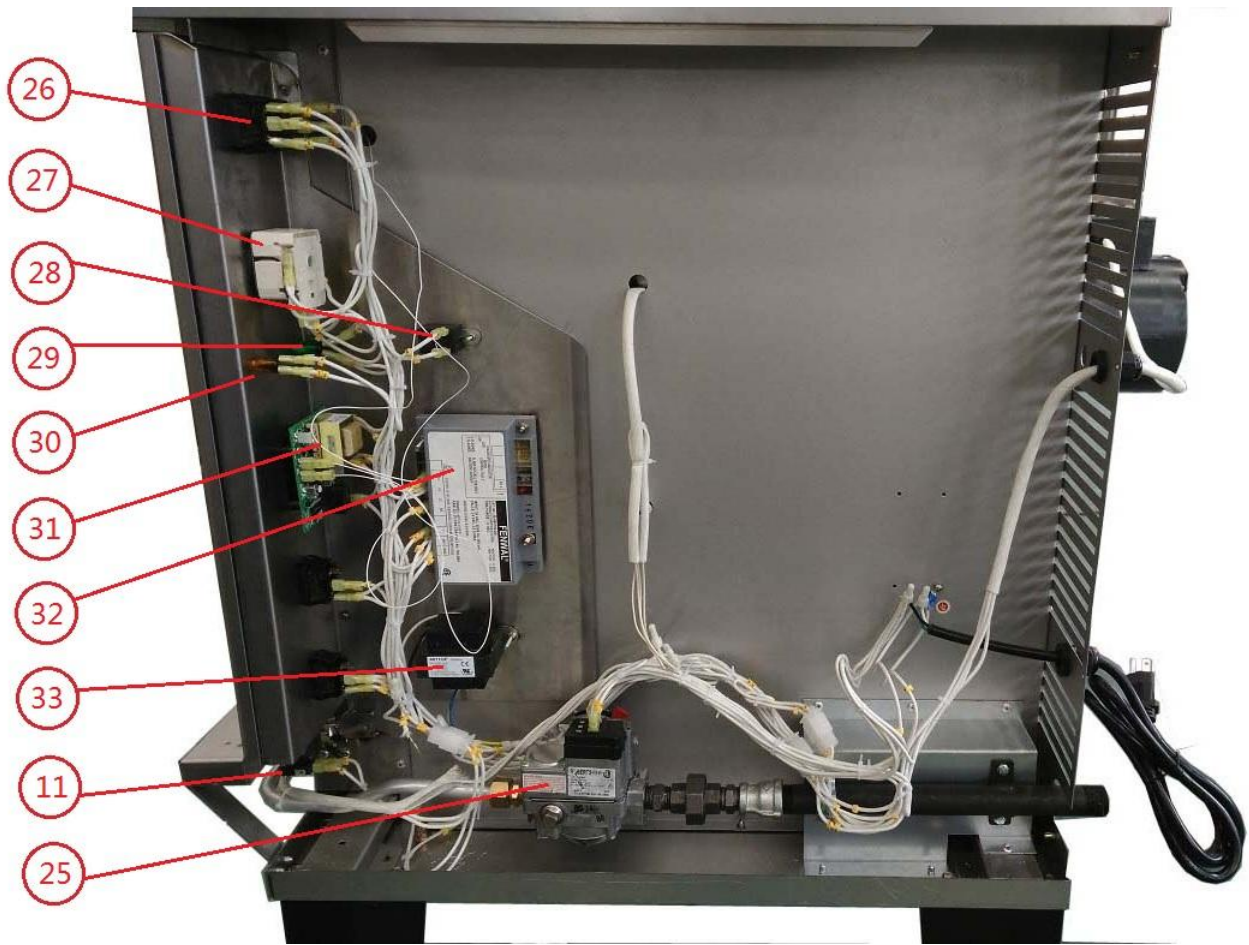

| NO. | PART NUMBER | Q'ty | DESCRIPTI ON |
|------------|-------------|------|----------------------------|
| 1 | FS-COP0001 | 1 | TOP DOOR GASKET |
| 2 | FS-COP0002 | 1 | SIDE DOOR GASKET |
| 3 | FS-COP0003 | 2 | DOOR LATCH ASSY. |
| 4 | FS-COP0004 | 2 | DOOR HANDLE |
| 5 | FS-COP0005 | 1 | LEFT DOOR ASSY. |
| 6 | FS-COP0006 | 1 | RIGHT DOOR ASSY. |
| 7 | FS-COP0007 | 2 | BURNER COVER |
| 8 | FS-COP0008 | 2 | BOTTOM GASKET |
| 9 | FS-COP0009 | 4 | CASTER |
| 10 | FS-COP0010 | 4 | LEG |
| 11 | FS-COP0011 | 1 | DOOR SWITCH |
| 12 | FS-COP0012 | 1 | VALVE TO BURNER PIPE ASSY. |
| 13 | FS-COP0013 | 40 | BODY SCREW |
| 14 | FS-COP0014 | 1 | CONTROL PANEL ASSY. |
| 15 | FS-COP0015 | 2 | INTERIOR LAMP HOUSING |
| 16 | FS-COP0016 | 4 | FAN GUARD & SCREW |
| 17 | FS-COP0017 | 1 | CAVITY FRONT PANEL |
| 18 | FS-COP0018 | 1 | FAN WHEEL |
| 19 | FS-COP0019 | 1 | CAVITY REAR PANEL |
| 20 | FS-COP0020 | 4 | PANEL BOLT |
| 21 | FS-COP0021 | 1 | FLUE |
| 22 | FS-COP0022 | 1 | MOTOR |
| 23 | FS-COP0023 | 4 | MOTOR BOLT |
| 24 | FS-COP0024 | 1 | MOTOR GUARD BRACKET |
| 25 | FS-COP0025 | 1 | GAS VALVE |
| 26 | FS-COP0026 | 3 | SWITCH |
| 27 | FS-COP0027 | 1 | TIMER |
| 28 | FS-COP0028 | 1 | BUZZER |
| 29 | FS-COP0029 | 1 | POWER GREEN LIGHT |
| 30 | FS-COP0030 | 1 | HEAT YELLOW LIGHT |
| 31 | FS-COP0031 | 1 | TEMPERATURE CONTROL MODULE |
| 32 | FS-COP0032 | 1 | IGNITION MODULE |
| 33 | FS-COP0033 | 1 | TRANSFORMER |
| 34 | FS-COP0034 | 1 | FLAME SENSOR |
| 35 | FS-COP0035 | 3 | NAT. ORIFICE |
| 36 | FS-COP0036 | 3 | BURNER |
| 37 | FS-COP0037 | 1 | BURNER MANIFOLD |
| 38 | FS-COP0038 | 1 | IGNITOR |
| 39 | FS-COP0039 | 1 | RACK |
| 40 | FS-COP0040 | 12 | LEG BOLT |
| 41 | FS-COP0041 | 1 | LP CONVERSION REGULATOR |
| * | FS-COP0042 | 1 | LP ORIFICE 55# |
| * | FS-COP0043 | 2 | INTERIOR OVEN HALOGEN LAMP |
| * | FS-COP0044 | 2 | TIMER OR TEMPERATURE KNOB |
| * NOT SHOW | | | |

REPLACING OVEN INTERIOR LAMPS (Use 40 Watt T4, 120 Volt Halogen bulb)

(see photos below)

To replace a lamp inside the oven:

1. Wait until oven is completely cool before performing this procedure.
2. Unplug power cord from power source.
3. Remove all racks and side rack guides on the lamp side of the oven.
4. Grab the underside of glass cover of the lamp you want to replace and pull outward. Cover will drop out of the top.
(See figure A)
5. Pull halogen bulb up out of the socket base.
(See figure B)
6. Replace with 40 Watt, T4 pin type, 120 Volt halogen lamp as shown in figure C.
7. Replace glass cover by inserting top of cover into the top of the lamp fixture. Push bottom back into place until it snaps in.



Figure A



Figure B



Figure C

Convection Oven

Natural to LP gas conversion Procedure

Unplug oven from power and disconnect from gas line.

Remove lower front burner cover.



Open doors and remove screws on top to remove cover

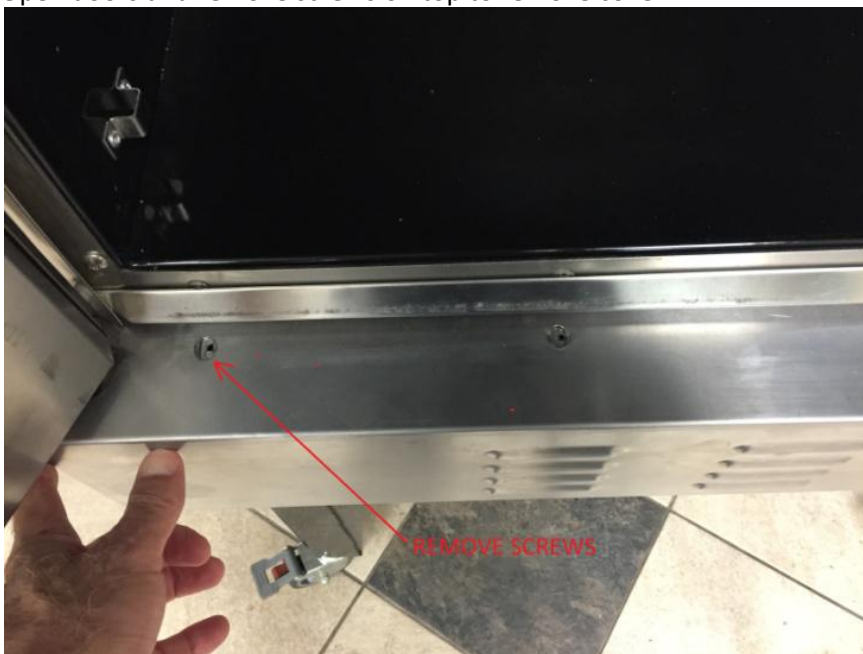



Swing control panel forward. To do this, reach under top and loosen control panel knob, then swing panel forward.



Remove side panel of oven next to control panel by removing screws on bottom and rear of oven to expose the gas system and electrical system.



This below, is what you will see.



On front of oven, use wrenches to loosen gas line connection to burner manifold.



Loosen nuts holding manifold pipe to bracket and remove screws in front of manifold bracket holding it to oven frame. Cut cable ties holding electrical wires to manifold assembly (remember where they are so you can replace them with new cable ties during reinstallation.)

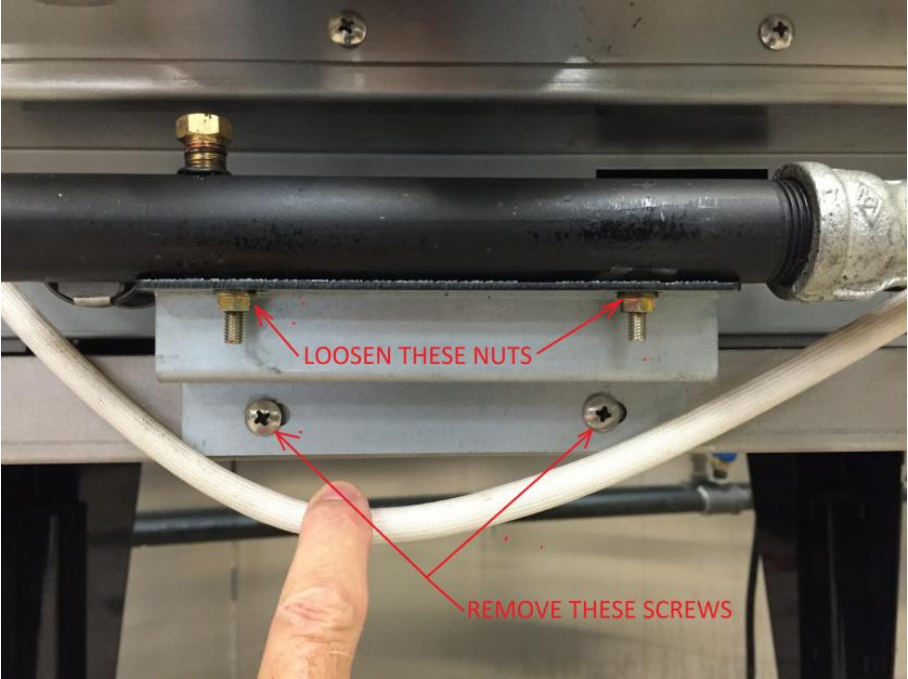

Pull manifold assembly off gas supply tube remove from oven.



Using wrench, remove existing gas orifices for Natural Gas, and replace with new LP Gas orifices supplied in conversion kit. Use Loctite 542 thread sealer or equivalent to seal and lock new orifice threads.



On side of oven, locate gas control valve. Locate regulator screw cover on top. (Scrape out soft silicone filling screw driver slot.) Use screwdriver to remove cover. See photo below:



After cover is removed, use a small screwdriver to carefully turn counterclockwise, the plastic spring retainer ring shown below.

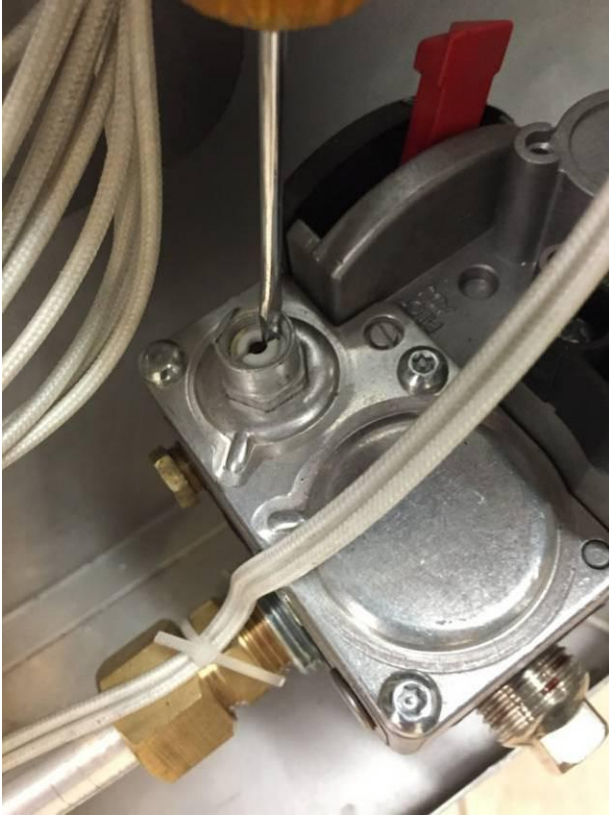

Keep turning until ring comes out and existing spring is exposed. Remove the spring.



Locate the new regulator kit.



Carefully remove the new spring in this bag, and place it where the old one was removed. Place the new spring retainer cap on top of the spring and carefully turn it clockwise to begin tightening the spring. Using a fine screwdriver, carefully tighten the retainer ring down until it is 0.20" (slightly less than 1/4" from the top surface of the spring assembly). This will set the regulator to the 11" W.C. needed to run the burners on LP gas.



To make sure pressure from regulator is correct, and to fine tune pressure, remove brass pipe plug on burner manifold and connect sensitive gas pressure gage to measure manifold pressure.

Reconnect manifold to gas tube and reinstall manifold in oven, making sure orifices are correctly centered in burners. Apply new cable ties to hold electrical wires to manifold.

Make sure all gas connections are tight and sealed. Reconnect oven to LP gas with maximum pressure coming into oven to be no more than 11" W.C. from external regulator in between gas tank and oven.

Plug oven into 120 volt outlet.

Turn on oven. Oven should light normally and operate normally if new regular spring and spring retaining cap were installed properly. Screw retaining cap down clockwise to increase pressure to manifold, turn counterclockwise to reduce pressure. When manifold is 11" W.C. as shown, flames and combustion will be optimized and you will see a good cooking.



Turn off oven. Remove oven from gas supply.

Remove gas gage from burner manifold and replace with original brass pipe plug.

On the control valve, replace the top cap with the new red cap supplied and apply the sticker (supplied) to the regulator that states it has been converted to LP gas operation.



Replace side cover.

Replace bottom burner cover.

Swing control panel back into normal position. Tighten retaining screw by hand on top of control panel to lock it into place.

End of conversion procedure.

CONVECTION OVEN

A product with the name incorporates the best in durability and low maintenance. We all recognize, however, that replacement parts and occasional professional service may be necessary to extend the useful life of this unit. When service is needed, contact a Authorized Service Agency, or your dealer. To avoid confusion, always refer to the model number, serial number, and type of your unit.

