

KOOL-IT

Signature

LX-74RB

TRIPLE GLASS DOOR MERCHANTISER REFRIGERATOR

Energy efficient, eco-friendly HC refrigerant with low charge, spark-free components, and the lowest utility costs in its category.



KEY FEATURES



• Eco-Friendly Refrigerant

Environmentally friendly R290 hydrocarbon refrigerant has low Global Warming Potential (GWP). Meets all USA, California & Canada refrigerant & energy standards.



• Intelligent Electronic Control

Patented ETC1H electronic controller assures optimal refrigeration performance through precision temperature control, and intelligent control for defrost cycle, compressor & other component functions.



• High Power Reliable Refrigeration System

Fast pull down, optimal internal air circulation and reliable refrigeration, maintaining cooler temperatures for food preservation.



• Standard LED Lighting System

Ultra bright low energy interior LED illumination system provides optimal merchandise display visibility. Low profile, door mounted, clip-in LED design.



• Newly Designed Condenser

New condenser featuring a joints reduction down to zero increasing long term refrigeration reliability and safeguarding against any system leaks.



• Spark-Free Refrigeration Components

All Reach-In models have spark free refrigeration components for optimal safety, per UL requirements.



NEMA 5-15P

Signature **40/80 Warranty**
40 months parts and labor
80 months on compressor (part only)



3560 NW 56th Street
Fort Lauderdale, FL, United States 33309
Telephone: 786.600.4687 / Toll Free: 844.218.8477
Fax: 786.661.4100

5659 Royalmount Ave.
Montreal, QC, Canada H4P 2P9
Telephone: 514.737.9701 / Toll Free: 888.275.4538
Fax: 514.342.3854 / Toll Free: 877.453.8832
sales@mvpgroupcorp.com / mvpgroupcorp.com



LX-74RB

TRIPLE GLASS DOOR MERCHANTISER REFRIGERATOR

PRODUCT VIEWS

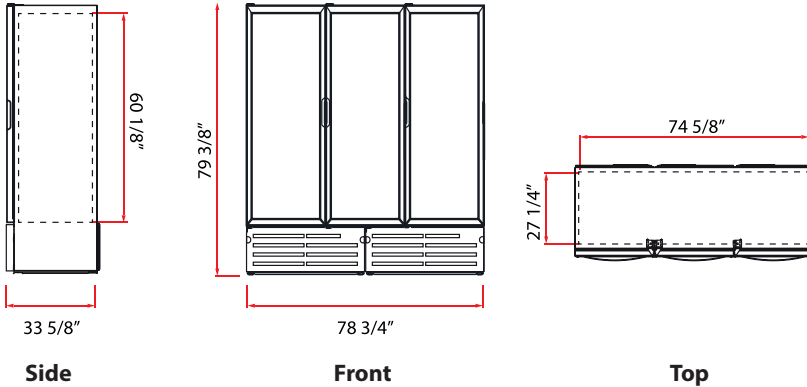

ADDITIONAL FEATURES



Manual Lock - External lock available



Gravity kit - Visi-Slide product display technology



Price Kit - Available for shelf display



Casters or legs are available options

TECHNICAL SPECIFICATIONS

Exterior Dimensions		Interior Dimensions		
W:	78 3/4" (200 cm)	W:	74 5/8" (190 cm)	
D:	33 5/8" (86 cm)	D:	27 1/4" (69 cm)	
H:	79 3/8" (202 cm)	H:	60 1/8" (152 cm)	
Usable Interior Capacity		Usable Volume		
W:	72 1/8" (183 cm)	66.3 Cu Ft 1878.4 L		
D:	21 5/8" (55 cm)			
H:	52 5/8" (134 cm)			
Doors	Material	Shelves	Shelf Size	
3	V7 Plastic Frame	15	W:	24 1/4" (62 cm)
			D:	22 1/8" (56 cm)
Exterior Material		Pre-painted steel		
Interior Material		Pre-painted steel		

REFRIGERATION PERFORMANCE

Refrigerant	Energy Consumption
R290 / 5.6 oz (0.160 kg)	5.004 kWh/24h
Compressor Power	Condenser
1/2 HP x2	Finless (low maintenance)
Thermostat default setting	32°F (0°C) to 44.6°F (7°C)

ELECTRICAL

Power Supply	Amps	Lighting
115V/60Hz	8.7A	242 Lux Output 27 modules, 8 LED per
Plug Type	Controller	Cord Length
NEMA 5-15P	ETC1H	128" (327 cm)

LOGISTICS

Trailer Loads	Unit Weight	Shipping Dimensions	
53': 18	815.7 lb (370 kg)	W:	81 1/4" (206 cm)
	Shipping Weight	D:	33 3/4" (86 cm)
	828.9 lb (376 kg)	H:	82 3/4" (210 cm)