



C2148 - 2000lb Cube Ice Machine

Prodigy Plus® Modular Cube Ice Machine

The world's smartest cuber.

As the world's only self-monitoring cuber, the new Scotsman Prodigy Plus® cube ice machines make it easier than ever to maintain your equipment and save money. Whether it's the advanced ice level control or an optional feature board for quick diagnostics, this is ice-making re-imagined. And with intuitive technology like AutoAlert™ indicator lights, a reduced operational footprint and easy-access service from the front panel, Prodigy Plus® cubers are simply the smartest, most reliable way to create fresh-tasting ice — every time.

The Prodigy Plus® difference.

- AutoAlert™ indicator lights for better visibility
- Operational footprint among the industry's smallest
- Industry-exclusive QR code instantly connects users to service information and warranty history
- One-touch cleaning reduces labor costs and saves time
- Front-located air filter for more efficient operation
- Self-aligning front panel for easy access to key components
- Patented WaterSense purge control automatically reduces scale buildup
- Patented Harvest Assist efficiently moves cube ice to the bin
- Smart-Board™ advanced feature module available for additional diagnostic capabilities
- Optional Vari-Smart™ ice level control allows operators to customize ice levels
- Antimicrobial protection guards internal surfaces between cleanings
- A full range of water- and energy-saving features



C2148 - 2000lb Cube Ice Machine



24 Hour Volume Production

| Remote | | Water Cooled | |
|------------------------|-------------------|------------------------|------------------------|
| 70°F/21°C 50°F/10°C | Air Water | 90°F/32°C 70°F/21°C | 70°F/21°C 50°F/10°C |
| 2248/1022 lb/kg | 1849/840 lb/kg | 2091/950 lb/kg | 1804/820 lb/kg |



Modular Bin Options

| Model Number* | Dimensions W" x D" x H" | AHRI Certified Bin Capacity lb/kg | Application Capacity lb/kg | Finish | Ship Weight lb/kg |
|---------------|-------------------------|-----------------------------------|----------------------------|-----------------|-------------------|
| BH1600BB | 60 x 34 x 62** | 1375/624 | 1755/796 | SS w/ GBB† | 370/168 |
| BH1600SS | 60 x 34 x 62** | 1375/624 | 1755/796 | Stainless Steel | 370/168 |



BH1600BB
BH1600SS

* Contact Scotsman for bin top requirements. ** Add 6" Height for bin legs.
† Stainless steel with galvanized back & bottom.



Cube Ice

Common ice form, ideal for mixed drinks.



Small Cube
7/8" x 7/8" x 3/8"
(2.22 x 2.22 x .95 cm)



Medium Cube
7/8" x 7/8" x 7/8"
(2.22 x 2.22 x 2.22 cm)



Certification



Warranty

- 3 years parts and labor on all components.
- 5 years parts and labor on the evaporator.
- 5 years parts on the compressor and condenser.

Warranty valid in North, South & Central America.
Contact factory for warranty in other regions.



C2148 - 2000lb Cube Ice Machine

Prodigy Plus® Modular Cube Ice Machine

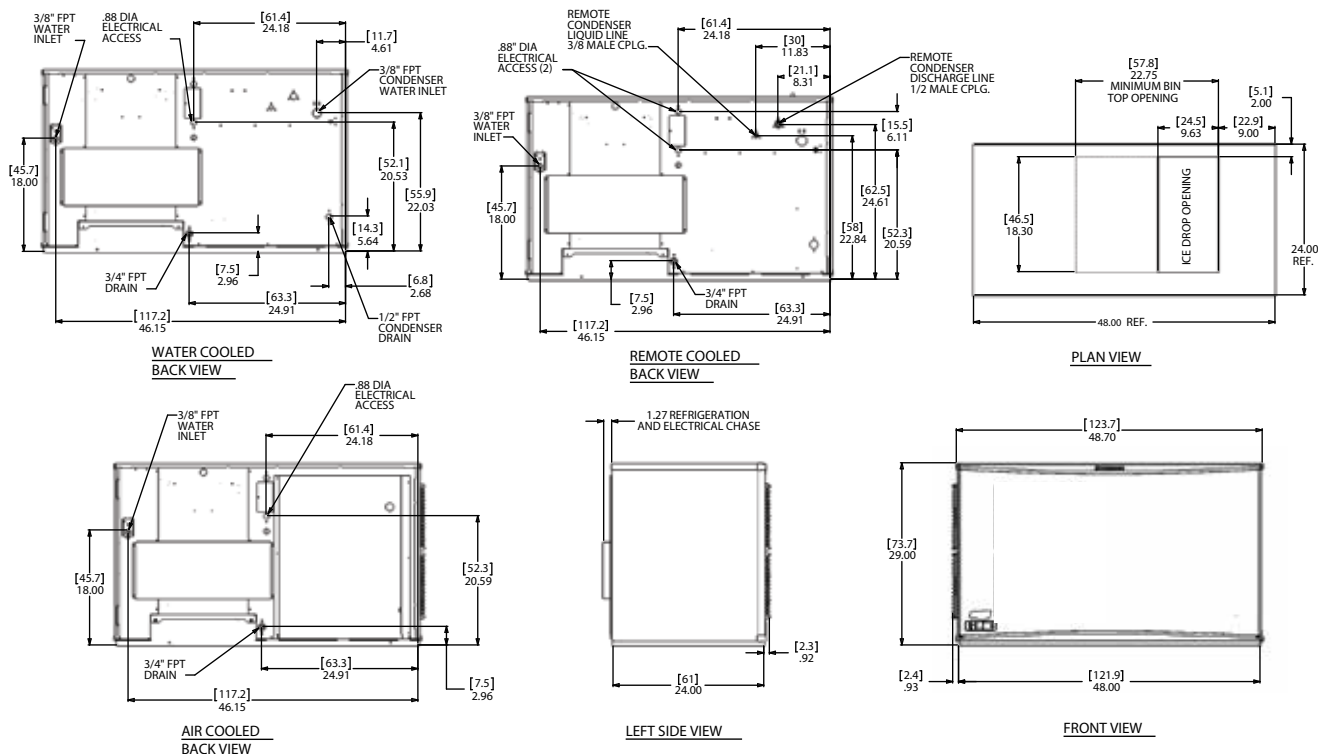

Specifications

| Model Number | Condenser Unit | Basic Electrical Volts/Hz/Phase | Max. Fuse Size or HACR Circuit Breaker (amps) | Circuit Wires | Min. Circuit Ampacity | Energy Consumption kWh/100 lb (45.4 kg) 90°F(32°C)/70°F(21°C) | Water Usage Gallons/100 lb (liters/45.4 kg) | | |
|--------------|----------------|---------------------------------|---|---------------|-----------------------|---|---|---------------------------------|--------------|
| | | | | | | | Potable 90°F(32°C)/70°F(21°C) | Condenser 90°F(32°C)/70°F(21°C) | Energy Star® |
| C2148MR-32 | Remote | 208-230/60/1 | 50 | 2 | 33.9 | 4.9 | 18.2/69.0 | - | - |
| C2148SR-32 | Remote | 208-230/60/1 | 50 | 2 | 33.9 | 4.9 | 18.2/69.0 | - | - |
| C2148SR-3 | Remote | 208-230/60/1 | 30 | 3 | 21.6 | 4.9 | 18.2/69.0 | - | - |



All Models

Dimensions (W x D x H):

Unit: 48" x 24" x 29"
(121.9 x 61.0 x 73.7 cm)

Shipping Carton: 51.5" x 27.5" x 34"
(130.8 x 69.9 x 86.4 cm)

Shipping Weight: 370 lb / 168 kg

BTUs per hour: 31,600

Refrigerant: R-404A



Accessories

| Model Number | Description |
|--------------|--|
| KVS | Vari-Smart™ Ice Level Control - Program ice bin levels to match ice needs. |
| KSBU | Smart-Board™ Advanced Control - Use additional operational data for fast diagnosis. |
| KSBU-N | Smart-Board™ Advanced Control with Network - Network capable. |
| ERC611-32 | Remote condenser for C2148xR, 208-230/60/1 - Consult remote condenser spec sheet for details |
| RTE10 | Line set, precharged, R-404A, 10ft. |
| RTE25 | Line set, precharged, R-404A, 25ft. |
| RTE40 | Line set, precharged, R-404A, 40ft. |
| RTE75 | Line set, precharged, R-404A, 75ft. |
| KPAS | Prodigy Advanced Sustainability Kit - Includes KVS and KSBU - N |

Scotsman recommends all ice machines have water filtration. See Scotsman water filter specification sheet for details.



Operating Requirements

| | Minimum | Maximum |
|--------------------|-------------------|-------------------|
| Air Temperatures | 50°F (10°C) | 100°F (38°C) |
| Water Temperatures | 40°F (4.4°C) | 100°F (38°C) |
| Remote Cond. Temps | -20°F (-29°C) | 120°F (49°C) |
| Water Pressures | 20 PSIG (1.4 bar) | 80 PSIG (5.5 bar) |
| Electrical Voltage | -5% | +10% |

Specifications and design are subject to change without notice.

Scotsman
ICE THE WORLD DEMANDS

C2148 - 2000lb Cube Ice Machine