



Project _____
 AIA # _____ SIS # _____
 Item # _____ Quantity _____ C.S.I. Section 114000



TU SERIES

44" Full Size Undercounter Refrigerators

Self-Contained

TU 44"



*Shown on optional casters



Listed by Underwriters Laboratories Inc., to U.S. and Canadian safety standards and Listed by NSF International.

AVAILABLE CONFIGURATIONS

One, Two & Three Door Refrigerator
 Models Available

Model	Model Type
TU044HT	1 Solid Door Refrigerator

STANDARD PRODUCT FEATURES

- Stainless Steel Exterior & Interior Finish
- Self-Contained System Using R-404A Refrigerant
- Reliable Microprocessor Control With LED Temperature Display
- Front-Breathing Design for "Zero-Clearance" Installation
- Non-Electric Automatic Condensate Evaporator
- Off-Cycle Evaporator Defrost
- Controllable Anti-Condensate Door Perimeter Heaters
- Metal Door Handle with Gasket Guard
- Self-Closing Door with Stay Open Feature
- Stainless Steel Field Rehingable Door
- 6" High Legs on Adjustable Channel System
- Standard Door Hinging: Right Hinging (other hingings available)
- Two (2) Shelves Per Door
- Magnetic Snap-In Door Gaskets
- Gasket-Protecting Stainless Steel Door Liner
- Thermostatic Expansion Valve Metering Device
- Side, Front & Rear Access Panel for Ease of Service & Maintenance
- 3-Year Parts & Labor Warranty
- 2-Years Additional Compressor Parts Warranty

ACCESSORIES & OPTIONS

- ▣ Remote Applications
- ▣ Stainless Steel Back
- ▣ Flat Stainless Steel Top with Bullnose Front
- ▣ Stainless Steel Top with 4" High Backsplash
- ▣ Stainless Steel Top with Drip Guard (Marine) Edge
- ▣ Set of 4" High Casters or 6" High Casters
- ▣ Drawers in Lieu of Door, set of 2 or 3
- ▣ Cabinet length extension sections in 3", 6", 9", 12", and 15" sizes

CONTINUED PRODUCT DEVELOPMENT MAY NECESSITATE SPECIFICATION CHANGES WITHOUT NOTICE.

Approved by _____ Date _____ Approved by _____ Date _____

FULL SIZE UNDERCOUNTER REFRIGERATORS



TU SERIES

Full Size Undercounter Refrigerators
Self-Contained

MODELS:
TU044HT

CLICK
TRANSFE
For KCL CADalog Website

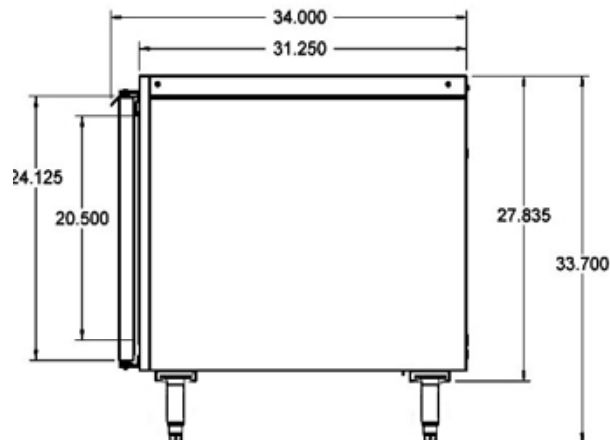
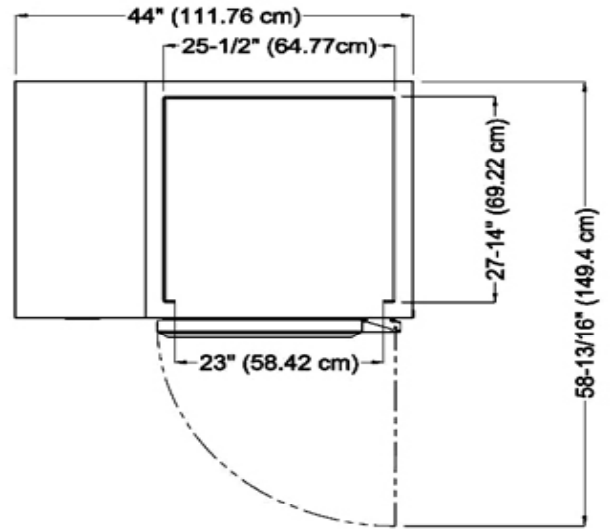
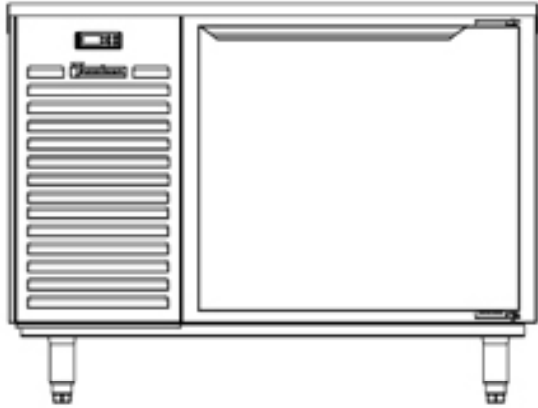

CONTINUED PRODUCT DEVELOPMENT MAY NECESSITATE SPECIFICATION CHANGES WITHOUT NOTICE.



Project _____
 AIA # _____ SIS # _____
 Item # _____ Quantity _____ C.S.I. Section 114000



FULL SIZE UNDERCOUNTER REFRIGERATORS

TU SERIES

44" Full Size Undercounter Refrigerators

Self-Contained

Door Models: TU044HT

EQUIPMENT SPECIFICATIONS

MODELS	TU044HT
CABINET DIMENSIONAL DATA	
Net Capacity cu. ft	9.8 (277 cu)
Length - Overall in.	44 (111.7 cm)
Depth - Cabinet Only in.	31 ^{1/4} (79.4 cm)
Depth - with Door Open 90 ⁰	58 (149.4 cm)
Depth - Overall in.	34 (86.4 cm)
Height - Overall on 6" Legs in. ¹	33 ^{7/10} (85.6 cm)
Height - Overall on 6" Legs in. ²	34 (86.4 cm)
Number of Shelves	2
Shelf Area sq. ft.	8.2 (.8 sq. m)
ELECTRICAL DATA & REFRIGERATION DATA 115/60/1 NEMA 5-15P	
Full Load Amps	6.3
MDEC ³	N/A
Refrigerant	R-404A
Refrigerant Amount oz. (gr)	18 (510 gr)
BTU/HR - HP ⁴	2440 (1/3 HP)
SHIPPING DATA	
Length - Crated in.	66 (167.6 cm)
Width Crated in.	42 (106.7 cm)
Height - Crated in.	38 (96.5 cm)
Volume Crated cu. ft.	61 (1727 L)
Weight lbs. (kg) - Crated	343 (155.6 kg)

CONSTRUCTION, HARDWARE, INSULATION

Cabinet exterior front, sides, one-piece louver assembly and doors are constructed of stainless steel. Cabinet interior and door liners are constructed of stainless steel. The exterior cabinet sub-top, back and bottom are constructed of heavy gauge galvanized steel. A set of adjustable 6" high stainless steel legs are included.

Doors are equipped with a gasket protecting metal door pan. A metal door handle with gasket guard is standard on all units. Both the cabinet and door(s) are insulated with an average of 2" thick high density, non-CFC, foamed in place polyurethane.

INTERIOR

Standard interior arrangements include two (2) wire shelves per door, mounted on shelf pins. Recommended load limit per shelf should not exceed 225 lbs. Optional tray slides may be purchased in combination with, or in lieu of these. Both standard and optional interior arrangements are completely installed at the factory.

REFRIGERATION SYSTEM

The self-contained, balanced refrigeration system using R-404A refrigerant features a hot gas evaporator defrost, thermostatic expansion valve, air-cooled hermetic compressor, plenum effect blower coil, large, high humidity evaporator coil located outside the food zone and an electric condensate evaporator. A 9' cord and plug is provided. Standard operating temperature is 34 to 38°F.

CONTROLLER

The easy to use water resistant microprocessor control system is supplied standard. It includes a 3-Digit LED Display, Fahrenheit or Celsius Temperature Scale Display Capability.

WARRANTIES

Both a three year parts and labor warranty and an additional two year compressor parts warranty are provided standard.



Equipped with one NEMA 5-15P Plug

NOTE: Figures in parentheses reflect metric equivalents.

1. Height as measured without optional stainless steel work top.
2. Height as measured with optional stainless steel work top.
3. MDEC= Maximum Daily Energy Consumption
4. Based on a 90 degree F ambient and 20 degree F evaporator.

*When ordering please specify: Voltage, Hinging, Options and any additional warranties.

Approved by _____ Date _____ Approved by _____ Date _____